

Local Plan

Supplementary Planning Document:

Residential Design Guidance

October 2016

Contents

1. Introduction	5
Background	6
Purpose of the SPD	6
Report structure	7
Monitoring	8
<i>PART 1 Background to Residential Design in Barnet</i>	9
2. Planning policy context	10
National policy	10
London Plan policies	10
Local Plan policies	11
3. Barnet’s residential character	11
4. Principles of good design	16
<i>PART 2 Design Aspects for New Residential Development in Barnet</i>	20
5. Housing density and building form	21
Achieving appropriate density	21
Design at different densities	21
6. Enhancing local character	22
Local character	22
Pattern of development	22
Building line and setbacks	23
Scale, massing and height	23
Materials, colour and architectural detailing	24
Boundaries	24
Gardens	25
Landscaping	25
7. Safeguarding residential amenity	27
Privacy and outlook	27
Sunlight, daylight and adequate ventilation	28
Safety and security	28
Lighting schemes	29
Reducing the visual impact of additions to building exteriors	29
8. Outdoor spaces	30
Outdoor amenity space	30
Design of outdoor amenity spaces	31
Front gardens	32
Balconies and roof gardens	32
Children’s play space	33
9. Structure and layout	34
Site layout	34
Internal space standards	34
Stacking of rooms and internal storage	34
Entrances and windows	35
Active frontages	35
Access	36
Movement	36
Legibility	37
Consider all users	37
11. Car parking, cycle storage and waste storage	37
Parking	38
Cycle storage	38
Waste and recycling storage	39
12. Design of basements	39
13. Residential development within town centres	40

PART 3 Design Guidance for Existing Residential Development in Barnet 43

14. Extensions to houses	43
Amenity	44
Harmony.....	44
Materials and details	45
Fitting into the street	46
Side extensions.....	46
Rear extensions	48
Front extensions	49
Dormer roof extensions.....	50
Large roof extensions	52
Roof lights	53
Detached ancillary buildings in front and back gardens	53
Front garden buildings	53
Back garden buildings.....	54
Basement extensions.....	54
Annexes to dwellings	55
Extent of extensions in Green Belt/ Metropolitan Open Land.....	55
Porches and canopies	56
Conversion of garages to habitable accommodation	57
15. Conversions	59
Houses in Multiple Occupation	60
Principles of Good Design	60
1. External appearance.....	60
2. Internal layout	61
3. Access to a garden	62
4. Car parking	63
5. Bin storage.....	63
6. Gas & electricity meter boxes	63
7. Security & crime prevention.....	63
16. Hardstandings and vehicular crossovers	64
Hardstandings.....	65
a. Preserving local character and retaining existing planting	65
b. Providing level access, ensuring safety and crime reduction	66
Vehicular crossovers.....	67
17. Planning permission and other issues	68
Planning permission.....	68
Design process and planning submission requirements	68
Other issues to consider	69
Conservation areas.....	69
Listed buildings	69
Green Belt and Metropolitan Open Land	70
Considering existing trees.....	70
Avoiding disputes with neighbours	71
Certificate of lawful development.....	71
Making a decision	71
Enforcement	72
PART 4 Appendices	73
Appendix 1: Building for Life 12	75
Appendix 2: Tables	75
Glossary	79
Further guidance	81
Other useful publications and websites	82
Useful contacts	83

Executive summary

Following adoption of the Core Strategy and Development Management Policies documents in September 2012 Barnet has one of the most up to date Local Plans in the country. With the support of a robust planning framework with clearly set out priorities of protection, enhancement and consolidated growth the council is in a strong position to produce more detailed local guidance.

Barnet's Residential Design Guidance Supplementary Planning Document (RDG SPD) provides a clear and consistent message on how we manage change within Barnet's suburbs. The SPD consolidates and updates the existing framework for residential design which mainly focused on improvements to the existing housing stock (Design Guidance Notes on Extensions, Conversions, Porches, and Hardstandings and Vehicular Crossovers).

This SPD provides more detailed residential design guidance issues relevant to Barnet such as local character, density, built form, car parking and amenity space standards connected with new build development. Through these changes the SPD sets out the local priorities for protecting and enhancing Barnet's character. It provides a local reference point to the suite of national guidance on good design.

1. Introduction

‘Housing developments should be of the highest quality internally, externally and in relation to their context and to the wider environment, taking account of strategic policies in the London Plan to protect and enhance London’s residential environment and attractiveness as a place to live’. (London Plan, Policy 3.5 – Quality and Design of Housing Developments)

Background

- 1.1 Barnet is an attractive borough which is largely suburban in character and contains a variety of density levels, buildings and townscape typologies which reflect its historical development. Its suburban character is mainly made up from a mix of detached, semi-detached and terraced housing and contains many good examples of historic residential developments for example in Hampstead Garden Suburb, Totteridge, Cricklewood Railway Terraces and Monken Hadley.
- 1.2 Following adoption of the Core Strategy and Development Management Policies documents in September 2012 Barnet has one of the most up to date Local Plans in the country. With the support of a robust planning framework with clearly set out priorities of protection, enhancement and consolidated growth Barnet is in a strong position to produce more detailed local guidance.
- 1.3 Barnet’s Three Strands Approach¹ highlights that the design, layout and use of the built environment can affect the quality of people’s lives as well as having an impact on the perception of Barnet as a place and on the vitality of the area. The council want to provide the right type of housing in the right places using the Local Plan to encourage developers to think creatively about design and layout solutions which respect the generally low rise suburban character of the borough. By doing this they can provide quality homes and housing choice which can help meet peoples’ housing aspirations.
- 1.4 Design has a strong role to play in the planning system, both in terms of plan making and decision taking. Good design is not simply a matter of preference or taste. It creates successful places capable of providing people with a good quality of life. Good design is fundamental to delivering many of Barnet’s planning objectives including managing housing growth to meet housing aspirations as well as the protection and enhancement of the suburbs. Therefore, this Supplementary Planning Document (SPD) provides greater details on the design aspects of residential developments as set out in Barnet’s Local Plan and the London Plan.

Purpose of this SPD

- 1.5 The council will not accept designs for new development that are inappropriate to their context or do not take opportunities to improve the character and quality of an area. High quality design solutions help to make new places in Barnet which can add to and complement the existing suburban character. Contemporary design may be appropriate provided it has regard to the local context.

¹ The Three Strands Approach defines the council’s place shaping priorities (Protection, Enhancement and Consolidated Growth) to planning, development and regeneration. It provides the spatial vision that underpins the Core Strategy and Barnet’s Local Plan.

- 1.6 This Residential Design Guidance SPD is aimed at all those involved in the planning, design and development of new housing. It will help architects and developers to formulate design proposals which are appropriate to Barnet’s suburban context. This SPD applies to all residential development in Barnet, regardless of tenure. Consideration should be given to the application at these standards alongside delivery of core strategy objectives. Viability and the need to ensure an appropriate level of housing supply in changing economic circumstances should also be considered. However a long term view is necessary as the homes and living environments we build today will frame the lives of those who live in new homes or use the neighbourhoods now and in the future.
- 1.7 At the end of each section, this SPD sets out principles for achieving good standards in residential design. It provides a local reference point to the suite of national guidance on good design. This SPD also sets out the requirements for Design and Access Statements and Building for Life appraisals.

Report structure

- 1.8 This SPD reflects the council’s general approach on residential design and is not intended to stifle sensitive and imaginative design. We recognise that as the fourth largest borough by area in London (amounting to 86.7km²) there is diversity in residential character, house type and architectural style within Barnet. It is therefore not practicable to cover every type of change or eventuality for new developments. Refer to section 17.9 -17.17 for special considerations in special areas such as Conservation areas, the Green Belt and Listed Buildings as well as to Section 3 of the document.
- 1.9 The Residential Design Guidance SPD is divided into four parts.
1. Part **one** sets out the context for residential design in Barnet providing, local design principles which reflect and contribute to the understanding of Barnet’s suburban character.
 2. Part **two** sets out general guidelines for new residential development as well as amenity and space standards. The document provides advice on privacy and overlooking, minimum room sizes, good building layout, provision of gardens, and outdoor play space requirements.
 3. Part **three** sets out the requirements and design criteria related to changes to the existing housing stock within Barnet. This supersedes the council’s existing Design Guidance Notes (DGNs) on Extensions (DGN 5, 2010), Residential Conversions (DGN7, 1994), Porches (DGN11, 1995) and Hardstandings and Vehicular Crossovers (DGN3, 2011).
 4. Part **four** includes provides supporting information including references, useful web links and the glossary list.
- 1.10 This SPD supplements policies contained within the Local Plan and the London Plan which together form the Development Plan for Barnet. The SPD is therefore a material consideration for decisions on planning applications. It has been prepared in line with the requirements of the Planning and Compulsory Purchase Act 2004 and associated regulations and guidance on Supplementary Planning Documents.

- 1.11 This SPD should be used alongside other adopted and future SPDs² and evidence base studies listed at the end of the document.

Monitoring

- 1.12 The implementation of this SPD will be monitored through Barnet's Local Plan Authority's Monitoring Report (AMR). We consider that successful implementation of the SPD should (a) reduce the number of cases subject to an appeal, by providing developers with a clearer framework for residential design and layout; and (b) improve the council's success rate at appeal in defending decisions against poor residential schemes.
- 1.13 The council does not consider that the cumulative impact of standards in this SPD should put implementation at risk as these standards facilitate development throughout the economic cycle. As economic circumstances change and familiarity with the SPD develops, the council may reassess the design categories in the document and the allocation of particular standards between them. These revisions to the SPD will be subject to consultation.

² See Local Development Scheme (LDS) for details of SPD production

PART 1

Background to

Residential Design in

Barnet

2. Planning policy context

‘Our standards of design can be so much higher. We are a nation renowned worldwide for creative excellence, yet, at home, confidence in development itself has been eroded by the too frequent experience of mediocrity....the planning system is about helping to make this happen....planning must be a creative exercise in finding ways to enhance and improve the places in which we live our lives’.
(National Planning Policy Framework, foreword)

National policy

- 2.1 The National Planning Policy Framework (NPPF, Mar 2012) sets out the Government’s planning policies for England including the presumption in favour of sustainable development. In the NPPF (paras 56 & 57) the Government attaches great importance to the design of the built environment. This is a key aspect of sustainable development, is indivisible from good planning, and should contribute positively to making places better for people.
- 2.2 The NPPF at para 58 emphasises that planning policies and decisions should ensure that new development:
- will function well and add to the overall quality of the area, not just for the short term but over the lifetime of the development;
 - establishes a strong sense of place, using streetscapes and buildings to create attractive and comfortable places to live, work and visit;
 - optimises the potential of the site to accommodate development, create and sustain an appropriate mix of uses (including incorporation of green and other public space as part of developments) and support local facilities and transport networks;
 - responds to local character and history, and reflects the identity of local surroundings and materials, while not preventing or discouraging appropriate innovation;
 - creates safe and accessible environments where crime and disorder, and the fear of crime, do not undermine quality of life or community cohesion;
 - is visually attractive as a result of good architecture and appropriate landscaping.

London Plan policies

- 2.3 London Plan (March 2016) Policy 2.6: Outer London: Vision and Strategy recognises that one of the key opportunities for Outer London is maintaining and enhancing the high quality of life that is already there. Delivery of ‘lifetime neighbourhoods’ is an important part of preserving this quality of life.
- 2.4 London Plan Policy 3.5 on Quality and Design of Housing Developments emphasises the importance of new housing development taking account of physical context and local character. This is supported further in London Plan Policy 7.4 Local Character which encourages a design approach that carefully responds to the whole context of a development and builds on an understanding of the place, the observation of existing assets, and the local authority’s existing vision or spatial strategy for the area. London Plan Policy 7.1 on Building London’s Neighbourhoods and Communities seeks to implement the principles of Lifetime Neighbourhoods which provide people with the best possible access to services, infrastructure and public transport and possess a character that is easy to understand and relate to.

Mayor's Housing SPG

- 2.5 The Mayor's Supplementary Planning Guidance (March 2016) provides detail to supplement the housing policies in the London Plan.
- 2.6 The SPG seeks to provide a convenient and accessible guide to implementing the key London Plan policies to housing development including quality and design. It contains information on design aspects of new housing developments at neighbourhood and dwelling levels. Requirements in the SPG are set out in terms of a 'baseline' standard and a 'good standard'. The document clearly states that any development failing to meet a number of baseline standards is unlikely to be acceptable.

Local Plan policies

- 2.7 Barnet's Local Plan Core Strategy (Sept 2012) provides the overarching local policy framework for delivering sustainable development in Barnet. The Local Plan Development Management Policies DPD (Sept 2012) sets out the borough-wide planning policies that implement the Core Strategy and is used for day to day decision making.
- 2.8 In relation to this SPD, the implementation of the following Local Plan **Core Strategy (CS) Policies** is important:
- CSNPPF - National Planning Policy Framework – Presumption in Favour of Sustainable Development
 - CS01 - Barnet's Place Shaping Strategy – Protection, Enhancement and Consolidated Growth - The Three Strands Approach
 - CS03 - Distribution of growth in meeting housing aspirations
 - CS04 - Providing quality homes and housing choice in Barnet
 - CS05 - Protecting and enhancing Barnet's character to create high quality places
 - CS06 - Promoting Barnet's town centres
 - CS09 – Providing safe, effective and efficient travel
 - CS12 - Making Barnet a safer place
- 2.9 The Core Strategy policies are further supported by the **Development Management Policies (DMP)**:
- DM01 - Protecting Barnet's character and amenity
 - DM02 - Development standards
 - DM03 - Accessibility and inclusive design
 - DM05 - Tall buildings
 - DM06 - Barnet's heritage and conservation
 - DM07 - Protecting housing in Barnet
 - DM08 - Ensuring a variety of sizes of new homes to meet housing need
 - DM09 - Specialist housing – Houses in Multiple Occupation, student accommodation and housing choice for older people
 - DM11 - Development principles for Barnet's town centres
 - DM15 - Green Belt and open spaces
 - DM17 – Travel impact and parking standards

3. Barnet's residential character

'The main source of supply to meet demand is largely provided by our suburban housing stock. We therefore need to protect such housing within established residential streets which, because of their rhythm and cohesiveness, contribute to local character.' (Barnet's Core Strategy, para 10.2.6)

- 3.1 The Barnet Characterisation Study (2010) was commissioned as part of the evidence base for the Local Plan to identify those areas of the borough that can accommodate growth and those that should be safeguarded. In examining the built environment the Characterisation Study highlighted the uniformity of suburban streets and the contribution of suburban detached, semi-detached and terraced houses to local character.
- 3.2 This SPD supports the policy framework to protect and enhance Barnet’s distinctive character which is set out in the Local Plan. The SPD focuses on those areas of the borough which make up the residential suburb and where most Barnet residents live. These are areas neither protected by a planning designation such as conservation area or Green Belt, nor prioritised for growth such as town centres, priority estates and regeneration and development areas. These areas are shown in Map 6 of the Core Strategy.
- 3.3 Further details on design guidance for the excluded areas from the study are set out in their respective design guidance documents. These areas are:
- Mill Hill East Area Action Plan (adopted 2009);
 - Colindale Area Action Plan (adopted 2010);
 - Brent Cross Cricklewood and West Hendon Development Framework (SPG adopted 2005);
 - The North London Business Park and Oakleigh Road South (planning brief adopted June 2006);
 - Priority housing estates at Dollis Valley, Grahame Park, Granville Road, Spur Road Stonegrove and West Hendon;
 - Priority town centres of Chipping Barnet, Edgware, Finchley Church End and North Finchley will have their own town centres framework/ strategies and development briefs. This SPD does cover planning and building parameters that may be applicable within town centres.
- 3.4 The design principles set out in the SPD apply throughout the Borough. In the event of a conflict between the SPD and a more detailed set of guidance in an Area Action Plan or Conservation Area Management Plan, then the latter shall prevail.
- 3.5 Barnet has 16 Conservation Areas. Detailed information and design guidance for these areas is contained within their adopted Conservation Area Character Appraisals (CACAs). Guidelines in this SPD are intended to address the general amenity and character considerations associated with householder development. However, where there is conflict between these guidelines and conservation area or listed building considerations, the CACAs considerations will prevail. Covering over a third of the Borough is the Green Belt and Metropolitan Open Land (MOL) that make a valuable contribution to Barnet’s character. Further information on Green Belts is provided in section 17.16.
- 3.6 The Characterisation Study focused on Barnet’s residential streets. These streets are characterised by houses facing onto a street, where pedestrian movement and vehicular movement are integrated. Residential streets from Table 1 were further assessed (in Table 2) in the Study in terms of density, building types and units, enclosure, street width, setbacks and building height, architectural treatment / style / period, landscape character / streetscape and topography. The application of these five criteria identified five primary and six secondary typologies as shown in Tables 1 and 2, which underline the special local distinctiveness of places that are worthy of protection from development.

Table1: Summary of Primary Typologies











	Photograph	Aerial	Scale and Grain	Land Use	Network Characteristics
Big Box			Large single building units (sheds) typically coarse grained and without an over-arching urban structure. Often surrounded in parking.	Industrial, retail, and leisure	Non permeable, typically unsuited for pedestrian movement.
Campus			Large building units set in landscaped open space	Education (universities and secondary schools), civic, business, office, hospitals and leisure.	Non permeable with limited pedestrian connectivity.
Cores and Town Centres			Medium-to-large building units arranged along streets forming strong terraces and coherent forms.	Mixed land use including retail, civic, residential, and office.	Permeable grid, based around strong street frontages and high levels of activity. Very well suited to pedestrian movement.
Residential Estates			Variable building scales, set in landscape and/or parking	Residential	Fine grain network of pedestrian routes, with a distinct lack of clear structure, hierarchy and legibility.
Residential Streets			Small-to-medium building units arranged along streets. Urban blocks tend to be large.	Residential	Permeable grid, although the scale of urban blocks limits the pedestrian connectivity.

Table 2: Summary of Secondary Typologies (1 of 2 pages)

	Density (Dwellings per hectare)	Density (Dwellings per hectare)	Density (Dwellings per hectare)	Building Types	Heights (Storeys)
Linear Rural			2 - 10	Detached houses	1 - 3
Suburban Periphery			10 - 15	Detached houses	2 - 3
Suburban			20 - 30	Semi-detached houses	2 - 3
Suburban Terrace			20 - 30	Terraced houses	2 - 3
Urban Terrace			37 - 50	Terraced houses	2 - 3
Flats			80 - 150	Street facing flats	3 - 6

Enclosure	Street Widths	Setbacks (building front from plot edge)*	Landscape character / Streetscape	Architectural Style / Period	Photograph
Street space is enclosed by trees, hedges and other vegetation	Narrow Street space / lane, with little or no pavement (15 - 20 metres)	Buildings are well set back (8 - 40 metres)	Typically leafy and rural, prominent vegetation with mature native trees and hedgerows.	Varied	
Street space is enclosed primarily by vegetation, as buildings provide secondary enclosure	Wide street space with pavement (11 - 13 metres)	Buildings are well set back (8 - 14 metres)	Leafy and exclusive character, as parking is well integrated into large front gardens. Front gardens contain an array of vegetation.	Varied	
Buildings provide primary enclosure to street.	Medium to wide street space, often with generous pavement (12 - 18 metres)	Buildings are well set back (4 - 9 metres)	Broad, open street profile with medium-sized front gardens primarily used for parking. Small trees evident on many streets.	Typically buildings from the interwar period	
Buildings provide primary enclosure to street.	Medium to wide street space with pavement (9 - 12 metres)	Buildings medium to well set back (4.5 - 7 metres)	Medium-sized front gardens primarily used for parking. Small trees evident on many streets.	Typically buildings from the interwar period, and occasionally late Edwardian. Houses influenced by Garden City movement also present.	
Buildings provide primary enclosure to street.	Narrow street space with pavement (10 - 11.5 metres)	Limited set back (1.5 - 3 metres)	Narrow street profile with shallow front gardens. Streets are dominated by cars with little room for vegetation.	Victorian and Edwardian buildings	
Buildings provide primary enclosure to street.	Wide street with pavement (4 - 13 metres)	Buildings well set back (5 - 17 metres)	Vegetation along the routes varies considerably in species and maturity. Front gardens have often been converted to hard standing	Typically post war blocks or Victorian and Edwardian mansions converted into flats	

4. Principles of good design

'In focusing on the quality of housing that is needed and the types of homes that are required in Barnet, we will consider sustainability, the efficient use of natural resources, standard of design and construction, contribution to local character and integration of the development with social, green and physical infrastructure'. (Barnet's Core Strategy, para 9.1.5)

- 4.1 The council recognises that achieving design quality is an important part of good planning. Every development is generally different in size, context, type and nature but the underlying principle is that the development needs to be designed to ensure it functions well, is pleasing to the eye and it endures. The council will, therefore, not accept design that is considered inappropriate to its context or which fails to take opportunities to improve the character and quality of an area and the way it functions.
- 4.2 The NPPF para 64 states that "Permission should be refused for development of poor design that fails to take the opportunities available for improving the character and quality of an area and the way it functions."
- 4.3 A number of core design principles are highlighted in para 10.5.5 of Barnet's Core Strategy. As highlighted in Table 3 below, there are a number of design documents that set out good design quality principles for the delivery of sustainable development through the planning system. Applicants and their advisors are required to take them into account at the preparation stage of their submission design statements.

Table 3: Overarching Design Documents

	Guidance	Principles	How to apply in Barnet
1	The Design Wayfinder, Design Council CABE, 2012 http://www.designcouncil.org.uk/sites/default/files/asset/document/dc%20-%20design%20wayfinder%20%281%29.pdf	The short ‘Design Wayfinder’ document helps planners and others make the case for good design, identifies the main sources of guidance and best practice on good design and the type of analysis required to decide whether proposed development is acceptable. The document provides help for authorities, developers and communities.	The council encourages all to make use of the ‘Design Wayfinder’ to help make the case for good design in planning. Applicants, their advisers and local communities are expected to take more responsibility for securing good design, and for taking the opportunities available to improve their area.
2	Building for Life12 (BfL12), Design Council CABE, 2012 http://www.hbf.co.uk/fileadmin/documents/briefings/BfL_A4_booklet_singlepages.pdf	BfL12 comprises of 12 questions, with 4 further questions in each chapter that reflect their vision of what new housing developments should be: attractive, functional and sustainable places. Redesigned in 2012, <i>BfL 12</i> is based on the NPPF and the Government’s commitment to build more homes, better homes and involve local communities in planning.	All applicants, developers and their architects will be expected to have regard to the <i>BfL 12</i> criteria in bringing forward new residential schemes. BfL12 questions are outlined in Appendix 1.
3	Barnet’s Sustainable Design and Construction (SD&C) SPD, 2016 http://www.barnet.gov.uk/downloads/download/518/sustainable_design_and_construction_spd_documents	Barnet’s SD&C SPD covers all technical aspects of the design and construction of buildings. It sets out what can be done in the current policy framework to design and construct new developments in ways that contribute to sustainable development.	All applicants, developers and their architects will be expected to have regard to the SD&C SPD in bringing forward new residential schemes.
4	By Design: Urban Design in the Planning System Towards Better Practice, CABE, 2000 https://www.gov.uk/government/uploads/system/uploads/attachment_data/file/7665/158490.pdf	Urban Design principles for example character, continuity and enclosure, quality of the public realm, ease of movement, legibility, adaptability and diversity should be addressed and promoted in all developments.	All applicants, developers and their architects will be encouraged to deliver the urban design principles as set out in the publication “By Design”. These overarching principles inform Barnet’s Development Management Policies DPD.
5	Safer Places: The Planning System and Crime Prevention, ODPM 2004 http://www.securedbydesign.com/pdfs/safer_places.pdf	This guide is informed by detailed case studies of successful, safe places, good practice pointers, attributes of sustainable communities that are particularly relevant to crime prevention. This guide challenges developers, designers and all those who influence the design and layout of developments, to think in a	Applicants and their advisors should pay close attention to the principles and practical details in this guide and apply these carefully to meet the needs of the local area and help to deliver the high quality and safe development that we all

		holistic manner about each development.	want to see and from which we can all benefit.
6	Secured by Design, Police initiative, Website Model http://www.securedbydesign.com/pdfs/SBDNewHomes2014.pdf	Secured By Design (SBD) is the UK Police flagship initiative supporting the principles of “designing out crime” through the use of effective crime prevention and security standards for a range of applications. SBD is owned by the Association of Chief Police Officers (ACPO) and is supported by the Home Office and the Planning Section of Communities and Local Government (CLG), as well as many Local Authorities across the UK. The Secured By Design Award is presented to a building owner or developer in recognition that the development was constructed in accordance with SBD standards.	Applicants and their advisors should ensure that measures to design out crime are integral to development proposals and considered early in the design process. This will ensure they provide adequate protection, do not compromise good design, do not shift the vulnerabilities elsewhere and are cost effective. In accordance with the London Plan policy 7.3, the Metropolitan Police should be consulted to ensure major projects contain appropriate design solutions.
8	Travel planning for new development in London incorporating deliveries and servicing, The Transport for London (TfL) 2011. http://travelpans.westtrans.org/wla/westtrans.nsf/Files/WTA-82/\$FILE/TfL%20Guidance%20-%20Travel%20Planning%20for%20new%20development%20in%20London%202011.pdf	The guidance sets out that local level residential travel plans must be submitted for any development with between 50 and 80 units and strategic level travel plans for developments equal or more than 80 units. This requirement applies to new developments, extensions or redevelopments of existing sites; and development that falls below the TfL thresholds but is considered to have the potential for significant traffic impact. This guidance is also appropriate for the creation of travel plans mixed-use developments where the residential element will have a significant impact on transport.	Any new residential development that meets thresholds as stated or has potential for significant traffic impact. Further detail can be found in Barnet’s Planning Obligations SPD and further advice can be sought from the L B Barnet Travel Plan Coordinator.
9	Principles of Inclusive Design (They include you), CABI, 2006 http://webarchive.nationalarchives.gov.uk/20110118095356/http://www.cabi.org/files/the-principles-of-inclusive-design.pdf	The document sets out the 5 key principles at the heart of inclusive design that help people use developments safely, with dignity, comfort, convenience and confidence. These principles will help provide people to make effective, independent choices about how they use a development without experiencing undue effort or separation.	Barnet council encourages all to make use of the key principles of Inclusive Design in their proposals. Applicants and their advisors are expected to take responsibility for securing good inclusive design where required.

PART 2

Design Aspects for

New Residential

Development in

Barnet

5. Housing density and building form

The 2016 London Plan ‘highlights the need for different types of affordable housing, and the need to look at the changing needs and demands for housing driven by a growing and changing population. This means recognising that housing isn’t just a numbers game’ (Mayor of London’s foreword to SPG on Housing, 2012)

Achieving appropriate density

- 5.1 Barnet’s approach is to optimise housing density in order to achieve appropriate development (see Local Plan Core Strategy Policy CS3: Distribution of Growth in Meeting Housing Aspirations). This is set within the context of the Sustainable Residential Quality Density Matrix in Table 3.2 of the London Plan. Density should not drive development, it is an important factor to take into account along with local context, design, transport accessibility and infrastructure.
- 5.2 Achieving appropriate densities is a major component of sustainable development and responding to a growing and changing population. The Characterisation Study identified six main housing typologies that largely reflect the pattern of residential development in Barnet. Table 2 sets out the key components of these six typologies including density, building type and height. Within the context of Table 2 low rise development and houses will normally be the most appropriate design solution for achieving appropriate densities in Barnet.
- 5.3 Appendix 2 provides further detail on the London Plan Sustainable Residential Quality Density Matrix. It sets out appropriate density ranges for suburban, urban and central locations which reflect the setting of a site in terms of its location, existing building form and massing and public transport accessibility level (PTAL).
- 5.4 For further information on density requirements for small sites and on developments outside the density ranges refer to section 1.3 of the Mayor’s SPG on Housing. Innovative design and layout solutions for new residential development will normally be encouraged and welcomed within the appropriate density range taking into consideration the unique features of the site as identified in Table 2 of this SPD and London Plan Table 3.2

Design at different densities

- 5.5 The quality of design is important for all developments, but particularly for higher density developments and all proposals should respond positively to reinforcing or improving local character. Failing to do this by simply adding standard house types together and reducing amenity space standards will not provide a quality living environment.

Principles

Ensure the:

- **design of new residential development relates to its setting and local character**
- **proposed density is suited to the site and to the wider context**
- **proposal responds positively to reinforcing or improving local character.**

6. Enhancing local character

'Planning policies and decisions should aim to ensure that developments...respond to local character and history, and reflect the identity of local surroundings and materials, while not preventing or discouraging appropriate innovation...' (National Planning Policy Framework, para 58)

Local character

- 6.1 An area's character may be derived from a range of attributes, including built form, architectural style, pattern, layout, space around buildings, landscaping, trees, streetscape, materials and uses/activity. The design and layout of new development should respect the character of the area in which it is situated and respond to the positive features of that character. In instances where the surrounding area lacks an identifiable character with positive attributes, or the proposal site is severed from its surroundings (i.e. by railway lines, major roads or industrial areas), the design of new development may establish a distinctive new local identity.
- 6.2 New residential development provides the opportunity to reinforce the character of an area by contributing and adding to the positive aspects of the built and natural environment. The council want new residential development to respect and enhance the positive features of Barnet's character and local distinctiveness. Respecting local character does not necessarily mean replicating it; however, great care should be taken when incorporating contemporary design into the existing urban fabric. New and old buildings can co-exist without negatively influencing the character of the area, but new development should always sit comfortably with its neighbours.
- 6.3 A more successful and appropriate development can result from a careful analysis of the local character and where relevant its history. Applicants should explain how the development proposal responds to the character of the site and wider area through a Design and Access statement.

Pattern of development

- 6.4 The pattern of development refers to the arrangement of plots, buildings and spaces around the building which, repeated over an area, forms part of that area's character and identity. In Barnet, as shown in Table 2, residential areas have a predominant suburban identity, characterised by houses set back from the road with front gardens, with generous gaps between the buildings. Corner plots often have greater space around the houses.
- 6.5 The pattern of development plays a vital role in:
- defining the character of the street;
 - influencing the perception of spaciousness and landscape capacity establishing daylight, outlook and privacy relationships between dwellings;
 - influencing the perception of safety on the street and the accommodation of parking, storage and service requirements.
- 6.6 The design and layout of new development should be informed by the local pattern of development. The continuity of building lines, forecourt depths, road layout, space about the building and rear garden areas are all likely to be significant factors when redeveloping sites within existing residential areas, or at the interface of larger development sites and existing housing.

- 6.7 A common arrangement of buildings in Barnet is the perimeter block structure, with the fronts of dwellings lining the street and private spaces such as gardens located at the rear of dwellings. This form of development offers several advantages:
- efficient use of land
 - legible and well-connected places
 - clear distinctions between public and private space
 - high levels of natural surveillance
- 6.8 Cul-de-sac forms of developments are generally discouraged; however they may be acceptable in certain cases provided they are shown to be part of a wider, well connected network. Within the general perimeter block structure, developments are encouraged to make use of creative and innovative layouts. However, the built up area within the block should be in character with the surrounding area and established building lines (both to front and rear) should be maintained. For example, the character of streets with detached or semi detached houses is informed by the gaps between buildings, and this rhythm of development should be maintained.

Building line and setbacks

- 6.9 A strong building line creates continuity of frontage and provides definition and enclosure to the public realm. Continuous frontages are most easily achieved with the Suburban Terrace and Flats typologies. With Suburban Periphery (detached houses) and Suburban (semi detached houses) typologies semi-continuous enclosure can be provided through the appropriate use of garages and walls. Where there is a strong building line, any new development should be in keeping with this. Where buildings have varied setbacks, this can add interest and variety to a street; however, boundaries should remain strong to give definition to the street and to ensure public and private space is clearly defined.
- 6.10 The setback of dwellings from a street is a key consideration. It can define the character of the street, determine the degree of privacy to ground floor rooms and can accommodate storage and service requirements at the front of the dwelling. Where dwellings can be serviced from the rear there may be opportunities for shallow setbacks or for building frontages to follow the back of pavement line. Careful thought needs to be given, in this instance, to the design of front doors and threshold areas, especially in relation to security.
- 6.11 The amount of set back should be determined by the surrounding character and road hierarchy. In case of infill areas, replication of existing pattern of set backs should be taken into account.

Scale, massing and height

- 6.12 Scale, massing and height refer to the arrangement, volume, shape, size and bulk of a building or a group of buildings in relation to other buildings and spaces; and their combined visual impact. It is these aspects of the built form which are fundamental to a proposals impact on its local character and also determine views, vistas and skylines. Proposals for new residential development should respond to the distinctive local building forms and patterns of development and respect the scale, massing and height of the surrounding physical context.

- 6.13 New development should recognise the scale, massing and roof form of surrounding buildings and reflect these where they are a positive attribute of the area's character. Consideration should be given to the grouping of buildings, roof pitches, the detailing of eaves and gables, chimney stacks and the size/siting of any dormer windows. New development should reflect the existing building lines and rhythm of the street. Where uniform building heights form a distinctive character, major variations will not normally be appropriate, in particular in the middle of a row of buildings.

Materials, colour and architectural detailing

- 6.14 The texture, colour, pattern and durability of materials chosen for new development contribute to the quality of its appearance individually, along with the character of its wider setting. Use of durable and high quality materials is fundamental to creating robust and sustainable residential development. Materials should be chosen which are able to withstand their environment, weather well over time and are likely to require minimal maintenance.
- 6.15 Poor quality materials that are hard to maintain will normally wear badly. Whilst high quality contemporary materials can create an attractive and distinctive character, all materials should respond to the site context and design objectives. Consideration should be given to the sourcing, energy efficiency and life cycle of the materials chosen. Use of permeable paving and porous materials is advisable for hard surfacing. Refer to Sustainable Design and Construction SPD (section 2.15) for further guidance on materials for surfacing.

Boundaries

- 6.16 Boundary treatments help to distinguish between public and private space within the public realm. This helps to convey use entitlement, clear ownership and maintenance responsibility, privacy and home security. The absence of clearly defined boundaries, especially along building frontages, can blur the edge between public and private space and lead to neglected, poor quality spaces between buildings and streets.
- 6.17 The permitted height of a means of enclosure is generally 1 metre adjacent to a highway and 2 metres elsewhere. This is the permitted development allowance. Generally, these heights will be appropriate in most suburban situations in Barnet except where the original character of an area is open plan, or where for example the return frontages of a corner property are enclosed up to a height of 2 metres. Boundary materials should reflect those prevailing in the area and the use of hedges and other green boundaries (preferably using native plant species) should not be obtrusive
- 6.18 In most cases, the fronts of houses should generally remain open to view in order to increase natural surveillance to the street, therefore walls, fences and hedges defining the fronts of properties should be kept low. Boundary treatments such as high railings and gates can be obtrusive and have a negative impact on the streetscene by conveying a sense of severance and overbearing. Side and rear boundaries can increase privacy and security to the property through higher fencing or walls. Front boundaries should reinforce the prevailing character of the streetscape, especially where a continuous uniform treatment forms a distinctive character. Boundary design should also complement the design materials and techniques used in the overall scheme. Consideration should also be given to pedestrian-vehicular intervisibility (stop line).

Gardens

- 6.19 Gardens make a significant contribution to local character and specifically towards biodiversity, tranquillity and sense of space. They also help to enhance the setting of buildings and provide amenity value for residents.
- 6.20 Where new development is considered detrimental to the site and local character, planning permission will normally be refused. The impact of development on the trees, biodiversity or habitat value of gardens will normally be considered as residential gardens make a significant contribution to biodiversity. Further details on improving ecological networks, green corridors, spaces and impacts will form part of Barnet's emerging SPD on Green Infrastructure. Further information on ecology is also provided in section 2.16 of the Sustainable Design and Construction SPD.
- 6.21 In relation to all developments including extensions and ancillary building(s) in back gardens, the implications of the presence or proximity of protected species and animals should be considered in line with the Wildlife and Countryside (as amended) Act 1981. Where necessary ecological surveys and suitable mitigation measures will normally be required. The scale of the requirement should be commensurate with the scale of the development. The use of water butts to collect rainwater for watering gardens could be added at design stage. Major residential development should normally utilise opportunities for ecological preservation and/or restoration as part of scheme design and layout, informed by an Ecological Statement.

Landscaping

- 6.22 Good quality, soft landscaping contributes positively to streetscape and local character. Trees and planting can have a softening affect on the appearance of hard materials of buildings and streets and can also provide increased privacy and security to homes. They can have significant benefits such as urban cooling and reducing overheating, absorbing rainfall and helping with climate change adaptation. Landscaping is a central aspect of design and should be considered early in the design process. A well-conceived landscape strategy will normally:
- assist in the creation of a distinctive sense of place;
 - provide an attractive focus within new housing areas;
 - provide safe and attractive play areas or informal play area;
 - provide a suitable interface with adjoining areas;
 - reduce the visual impact of roads and parking areas;
 - reinforce local landscape character and reduce flooding; and
 - make provision for Sustainable Urban Drainage Systems (SUDs) where appropriate. Refer to 2.15.2, Table 2.15.1 (on SUDS) of the SD&C SPD.
- 6.23 In order to maximise the benefits that open spaces can deliver it is vital that they are considered as a network. The Core Strategy (Table 5) sets out the components of Green Infrastructure in Barnet. Further guidance on ensuring improvements to the network of open spaces will be set out in the Green Infrastructure SPD.
- 6.24 Particular consideration should be given to the unique features of the development site, including soil types, drainage, light and the relationship with neighbouring properties. Thought should be given to ongoing maintenance, particularly planting close to buildings.

Soft landscaping should aim to protect existing trees and integrate them into new layouts and incorporate locally native species in new planting. Landscape design should be integrated within the building design from the earliest stage.

Principles

Ensure new development:

- complements or improve the character of the area through its appearance, architectural detailing, siting, use of materials, layout and integration with surrounding land, boundaries, building lines, setbacks, fronts and backs
- responds to distinctive local building forms and patterns of development by respecting scale, massing and height of surrounding buildings
- chooses high quality materials that are durable and simple to maintain and that they respond to local context and design objectives
- is not detrimental to the biodiversity of an area and amenity spaces of existing and future occupants
- boundaries should be used as it helps maintain and convey clear ownership, privacy, home security and street character
- provides appropriate landscaping from the earliest stage, retaining existing trees and incorporating locally native species into the scheme where possible.
- aim to reduce any impacts on the surrounding natural environment by providing adequate -naturalised buffer zones, free of all development, adjacent to sensitive areas (e.g. rivers) and reduce flooding through the use of Sustainable Drainage Systems (SuDS).

7. Safeguarding residential amenity

‘Schemes which significantly harm the amenity of neighbouring occupiers will be refused planning permission. Protecting amenity helps to protect the well being of the boroughs residents. It is important to ensure that developments do not significantly overshadow neighbouring buildings, block daylight, reduce sunlight, or result in a loss of privacy or outlook.’ (Barnet’s Development Management DPD, para 2.7.1)

Privacy and outlook

- 7.1 Privacy is an important design issue, particularly for higher density schemes, and all residents should feel at ease within their home. Design can create privacy in a number of ways, including the careful positioning of buildings in relation to one another, internal layouts (positioning of windows and rooms requiring more privacy) and through screening and landscaping.
- 7.2 The positioning of homes, including their windows and balconies, should be carefully considered to ensure that adequate privacy is maintained. In particular, habitable rooms and areas of private gardens close to dwellings should not be excessively overlooked by windows or elevated amenity areas such as balconies/terraces. Screening can reduce overlooking in these instances. Refer to the Sustainable Design and Construction SPD (section 2.4) for further guidance on privacy and outlook.
- 7.3 Privacy can be safeguarded by achieving adequate window to window, or window to balcony distances between buildings (both existing and proposed). In new residential development there should be a minimum distance of about 21 metres between properties with facing windows to habitable rooms to avoid overlooking, and 10.5 metres to a neighbouring garden. Shorter distances may be acceptable between new build properties where there are material justifications.
- 7.4 Design solutions through layout of habitable rooms, window placement and building orientation should be used to address privacy and overlooking issues. Use of opaque glazing should be kept to a minimum.
- 7.5 Clearly a balance has to be made between minimising loss of privacy and maximising security through surveillance. Where overlooking is a problem, especially in relation to neighbouring development, a higher degree of privacy will normally be required. All habitable rooms should contain at least one main window with an adequate outlook where nearby walls or buildings do not appear overbearing or unduly dominant. Refer to guides listed in para 7.11 for guidance on how to achieve the balance between privacy and security.
- 7.6 In higher density schemes such as in regeneration areas, where less distance is provided, innovative design solutions should be used so as to avoid overlooking, such as: angled windows, careful choice of window locations, obscured glazing, use of level changes, staggering of windows, screening and single aspect dwellings (only where the above cannot be applied).
- 7.7 The Mayor’s Housing SPG standard 29 highlights the benefits of having homes with windows which open on two sides. A dual aspect dwelling is defined as one with opening windows on two external walls and they offer many inherent benefits including: an increased amount of daylight, there is greater opportunity to gain direct sunlight for longer

periods, natural cross ventilation which also mitigates pollution, a choice of views, access to a quiet side of the dwelling, greater flexibility in the use of rooms, more potential for future adaptability by the altering the use of rooms.

Sunlight, daylight and adequate ventilation

- 7.8 Providing good daylight to the home not only contributes to a more pleasant living environment, but also has the potential to reduce energy requirements for lighting and heating. Careful orientation and design of buildings can ensure daylight and sunlight levels are maximised, without compromising levels of privacy of adjoining properties and reducing their daylight and sunlight levels.
- 7.9 New development should be sited and designed to maximise daylight and sunlight as far as possible. North facing single aspect units are normally unacceptable. Refer to Sustainable Design and Construction SPD (table 2.4) for further guidance on standards affecting daylight and sunlight.

Safety and security

- 7.10 The manner in which building design relates and responds to the adjacent street and public realm plays a significant role in influencing perceptions of safety and the risk of crime, both for the building occupants and people making use of these public areas.
- 7.11 Well thought out designs incorporating security features such as the provision of suitably designed lighting of entrances, rear accesses, and communal lobbies or hallways are one way to help reduce the risk of crime. All developments should seek to improve community safety and crime prevention. Buildings should face onto streets, and open spaces (overlooking areas for car parks) should be overlooked by windows. A critical element in designing out crime is providing for adequate natural surveillance, via easy overlooking. For example, schemes should provide for overlooking onto and from front gardens, commercial frontages, pathways, streets, communal amenity areas and car parking spaces; especially from windows in front elevations. Such overlooking enables surveillance which discourages the types of crime which rely on secluded areas. During the design stage, special attention should be given to aspect such as access and movement, structure, surveillance, ownership, physical protection, activity and management and maintenance.
- 7.12 The Police initiative “Secured by Design focuses on crime prevention at the design, layout and construction stages of development by seeking to ‘design out crime’. Safer Places and Secured by Design guides provides information on designing out crime solutions. It is important to also account for local conditions regarding safety and security during the building design stage. Refer to Table 3 for further details on Secured by Design and safer Places guides.
- 7.13 Secured by Design, Section 2 has now been incorporated into the updated Building Regulations Part Q: Security.
- 7.14 **Standard 13 of the Housing Supplementary Guidance** - An access core serving 4 or more dwellings should provide an access control system with entry phones in all dwellings linked to a main front door with electronic lock release. Unless a 24 hour concierge is

provided, additional security measures including audio-visual verification to the access control system should be provided where any of the following apply:

- i. more than 25 dwellings are served by one core, or
- ii. the potential occupancy of the dwellings served by one core exceeds 100 bed spaces, or
- iii. more than 8 dwellings are provided per floor

Lighting schemes

7.15 Lighting can affect amenity by creating light spillage and increasing glare. Proposals involving new lighting should not significantly impact on residential amenity and local biodiversity. Proposals should seek to minimise any adverse impact of lighting schemes through design or technological solutions or by controlling the hours of use. Solutions may include lighting that controls and manages the distribution of light and minimises glare. Design solutions could include screening, shielding and reducing lantern mounting heights. The visual impact of light fittings should also be considered. Further guidance is set out in the Sustainable Design and Construction SPD (section 2.4.4 and useful references).

Reducing the visual impact of external additions to building

7.16 External services such as multiple flues, ventilation pipes, meter cupboards and mail boxes on the outside of a building often detract from the finished appearance of an otherwise well designed development. In multiple-occupancy developments, such as blocks of flats, the building design should incorporate measures for the discreet accommodation of these services. Such measures can include recessed channels for down-pipes or routing of flues/outlets to non-sensitive elevations. Flues, ventilation units and other services that appear as 'add-on' elements will not normally be accepted.

7.17 Satellite dishes are similarly visually obtrusive especially on blocks of flats. Buildings intended for multiple occupation will normally be required to make provision as part of the building design for the communal provision of satellite and similar domestic telecommunications apparatus in discreet locations. In other cases satellite dishes should be of 'standard' size for television reception, positioned discreetly, such as on a non-exposed rear elevation, and located so as not to impact unduly upon the outlook of neighbouring properties.

7.18 On new housing development the council will normally seek to restrict permitted development for freestanding satellite dishes and require details of shared systems as a condition of planning permission. Satellite dishes should be removed as soon as they become obsolete. Satellite dishes will not normally be permitted on the front elevations of buildings within conservation areas or on listed buildings. Satellite dishes should be :

- as small in size and as few in number as possible
- shared by as many users as is feasible to avoid clutter. In most cases only one satellite dish per building will normally be approved. Communal telecommunications should be provided for all major developments.
- located as unobtrusively as possible
- of a colour and design to blend in with their background
- located so as not to interfere with doors or windows of neighbouring properties
- removed as soon as they become obsolete.

Principles

All developments should:

- be designed to ensure the provision of sufficient privacy, minimisation of overlooking between surrounding dwellings and orientation of buildings to maximise sunlight and daylight
- have sufficient distance between properties with facing windows to habitable rooms to avoid overlooking and to respect neighbouring gardens. Refer to Table 2.4 of the SD&C SPD.
- ensure that it does not reduce the amenity value of neighbouring occupiers
- have access to high quality and usable amenity space that is not overlooked from the public realm
- ensure buildings are designed in such ways that help mitigate opportunities for crime and fear of crime
- incorporate measures for the discreet accommodation of external services.

8. Outdoor spaces

'always seek to secure high quality design and a good standard of amenity for all existing and future occupants of land and buildings.' (National Planning Policy Framework, para 17)

Outdoor amenity space

- 8.1 Outdoor amenity space provides opportunities for recreation, leisure, tranquillity and overall quality of life as well as interaction with the natural environment. Back gardens and other outdoor amenity spaces contribute positively to Barnet's green character and spacious layout as well as helping to mitigate climate change. Provision of outdoor amenity space is vital in Barnet and a key consideration for new residential developments. Further details on technical requirements are provided in the Sustainable Design and Construction SPD (section 2.3.5)
- 8.2 Private amenity space for the exclusive use of building occupants is a highly valued asset. Sufficient, functional amenity space should therefore be provided for all new houses and flats wherever possible. Every home should have access to suitable private and/or communal amenity space through one or more of the following: private gardens, communal gardens, courtyards, patios, balconies and roof terraces.
- 8.3 **Standard 5 (and Policy 3.6)** – For developments with an estimated occupancy of ten children or more, development proposals should make appropriate play provision in accordance with the Mayor's Play and Informal Recreation SPG.LP Policy 3.5 supports a presumption against garden development where this can be locally justified. This is in recognition of the wider roles gardens play in London
- 8.4 Standard 3 - Development proposals should demonstrate that they comply with the borough's open space strategies, ensuring that an audit of surrounding open space is undertaken and that where appropriate, opportunities to help address a deficiency in provision by providing new public open spaces are taken forward in the design process.

- 8.5 All private outdoor space should have accessible threshold from the home (Balconies and terraces over habitable rooms which require a step up to increase slab thickness/insulation are exempt from the accessible threshold standard).
- 8.6 All private outdoor space should also ensure a good external noise level in line with the British Standards BS8233: 2014 – for further detail see section 2.14 of the Sustainable Design and Construction SPD.

Design of outdoor amenity spaces

- 8.7 New development should be sited and designed such that there is no detriment to existing residential amenity space through the overlooking and/or privacy loss; and dominance or overshadowing. The fundamental design considerations for amenity space should be its quality and usability. Applicants are expected to demonstrate these design considerations in their proposals.
- 8.8 In designing high quality amenity space, consideration should be given to privacy, outlook, noise, sunlight, trees and planting, materials (including paving), lighting and boundary treatment. All dwellings should have access to outdoor amenity space that is not overlooked from the public realm and provides a reasonable level of privacy. The size, shape and slope gradient of amenity space is key to its usability. Awkwardly shaped, narrow and very steeply sloping amenity spaces should be avoided and will not be considered to count towards usable outdoor amenity space.
- 8.9 Communal amenity space should:
- receive adequate sunlight relative to the defined purpose of the space
 - provide sufficient shade where necessary;
 - ensure a good external noise level in line with the British Standards BS8233: 2014 – for further detail see in section 2.14 of the Sustainable Design and Construction SPD.
 - be screened from parking and public areas to ensure privacy but still providing reasonable views to public amenity space;
 - be easily accessible and legible (easy to understand) to all occupants;
 - be overlooked by habitable rooms to ensure safety;
 - include seating, trees and planting, lighting, paving and footpaths (where appropriate);
 - have an effective and affordable landscape management and maintenance regime;
 - take account of the needs of disabled people and all age groups; and
 - have a clearly defined purpose and be designed to reflect this.
- 8.10 Standard 4 - Where communal open space is provided, development proposals should demonstrate that the space:
- a is overlooked by surrounding development;
- b is accessible disabled people including people who require level access and wheelchair users;
- c is designed to take advantage of direct sunlight;
- e has suitable management arrangements in place.

- 8.11 The rigid application of amenity space standards can sometimes restrict creative design and layout of new residential developments, particularly on smaller development sites. Developers are encouraged to bring forward schemes involving imaginative and innovative provision of outdoor amenity space on smaller sites. For all other sites, the minimum outdoor space standards for Barnet are highlighted in Table 2.3 of the Sustainable Design and Construction SPD as well as Appendix 2 (Table 1.2) of this SPD.
- 8.12 Proximity to public open space will only be considered when assessing the adequacy of provision of private amenity space where design and layout is of insufficient high quality and contributions are made through S106 contributions for enhancements to existing, nearby open space. Barnet’s Planning Obligations SPD³ sets out the S106 criteria requirements for open spaces. These contributions are separate from and in addition to any contribution that is required where a development is located in an area of open space deficiency.
- 8.13 Rear private gardens should provide adequate space for day to day uses such as a table and chairs for outdoor dining, clothes drying, relaxation and safe children’s play (where family accommodation is proposed).
- 8.14 Communal outdoor amenity space should be designed to provide a private, attractive, functional and safe environment. Its overall quality and management can help create a sense of ownership and pride. All private and communal amenity space should have a clearly defined purpose.

Front gardens

- 8.15 Front gardens or ‘set-backs’ (as highlighted in Table 2) are normally expected to be provided in residential developments, with careful consideration given to their design where it is not detrimental to the street scene and local character. When defined by a boundary, such as a hedge or low wall, front gardens provide a buffer between the public and private realm and provide clarity of ownership. Front gardens do not normally offer quality private amenity space.
- 8.16 Front gardens support the streetscape and enhance local character through landscaping, including trees, and can be sufficient to accommodate bin and cycle storage. Furthermore, they provide increased privacy and security to the ground floor front rooms of houses. Areas at the front of buildings should consist of permeable surfaces with consideration given to trees and planting. For changes to front gardens and the cumulative impact of such changes on local character together with guidance on where planning permission is required, refer to para 2.10.7 of the Development Management Policies document.

Balconies and roof gardens

- 8.17 In circumstances where it is not possible or appropriate to provide private gardens and communal amenity space suitable alternative arrangements should normally be made. Balconies and roof gardens will normally be acceptable alternatives where they do not result in overlooking which has a negative impact on the privacy of neighbouring residents or other occupiers within the development. Where balconies and other private spaces are

³ See timetable for production in LDS

accepted as the only form of amenity space to be provided within a development, they should normally be at least 1.5 metres (1500 mm) in depth and width in line with the Mayor’s Housing SPG Standard 27.

- 8.18 An internal, communal amenity space, such as an atrium, may also be a practical alternative. Where alternatives to outdoor amenity space are appropriate they should be of equivalent value in terms of amount, usability and accessibility. Internal communal amenity spaces should normally benefit from natural daylight and sunlight. S106 planning obligations will be considered from developments which do not meet the required on-site amenity standards.

Children’s play space

- 8.19 Children’s playspaces should be provided in all new residential development containing flatted schemes with the potential for 10 or more child bedspaces, as set out in the London Plan’s SPG Shaping Neighbourhoods: Play and Informal Recreation, Sept 2012. Play spaces should be designed to be overlooked for natural surveillance and with safety and security in mind. Policy DM02 sets out Barnet’s requirements for playspaces.
- 8.20 Residential development in areas of playspace deficiency as well as those in areas with sufficient playspace will normally be expected to make a contribution either on site or financially for playspace. Further information on areas of deficiency in Barnet and relevant maps, refer to Barnet’s S106 Planning Obligations SPD.

Principles

Ensure all developments:

- **have sufficient, functional and accessible high quality and usable outdoor amenity space away from general public areas, involving imaginative and innovative designs**
- **clearly define the boundaries between public, private and communal spaces to provide clear ownership and responsibility for their maintenance**
- **provide appropriate set-backs, with careful consideration given to the streetscape and residential design**
- **where the provision of private gardens and communal outdoor amenity space is not possible, alternative arrangements such as balconies, roof gardens should be of sufficient size and not result in overlooking**
- **children’s play spaces should be provided in accordance with the London Plan Shaping Neighbourhoods SPG. Barnet’s Planning Obligations SPD should be followed for any off site contributions.**

9. Structure and layout

'Some of the most attractive and enduring residential environments have the simplest of structures.'
(CABE, *Better Places to Live by Design*)

Site layout

- 9.1 Layout refers to how buildings and public and private spaces are arranged on a site, and how they relate to the buildings and space around the site. The layout informs the character and uniqueness of a place, and provides the basic framework on which all other aspects of the development depend.
- 9.2 Barnet's streets consist of grid, perimeter or block structures, characterised by a framework of interconnected routes that define street blocks, as is typical of outer London suburban locations. In most cases, new developments should respond to the traditional street pattern that exists in the borough. Table 2 shows that the layout of housing within blocks can range from terraces to detached homes. New development should take account of the block size and structure of the area surrounding the site.
- 9.3 In Barnet, some of the most attractive and enduring residential environments have the simplest of structures. In a classic street block structure, houses face the street, gardens run end-to-end and cars are mainly parked on the street. The sense of quality comes from the detailed design of the buildings, the corner and boundary treatments and from the mature landscape. Layout in major developments plays an important role in defining the overall structure of the area. Structure consists of the arrangement and inter-relationships between streets, houses, gardens, open spaces and areas for car parking.

Internal space standards

- 9.4 The council expects a high standard of internal design and layout in residential development. New homes should be capable of providing a good quality living environment that meets housing aspirations. The minimum residential space standards for new homes (Appendix 2, Table 1.3) will normally be applied to all developments in Barnet including conversions
- 9.5 The standards will help guide the appropriate number of dwellings that can be delivered by a residential development. With regard to conversions the constraints associated with existing building layouts will require some flexibility and pragmatism at the margins of each space standard. The internal layout of the dwellings should normally also comply with the relevant provisions of the Mayor's SPG on Housing.

Stacking of rooms and internal storage

- 9.6 Increased levels of occupancy of residential properties together with changing lifestyles, such as flexible home working means the design and layout of development should minimise the potential for noise transfer between new homes. In blocks of flats the technical provisions of the Building Regulations should be supplemented with the careful arrangement of rooms. The vertical stacking of rooms between flats should as far as practical ensure that bedrooms do not overlap living rooms, kitchens and bathrooms on

other floors. Where possible, the horizontal arrangement of rooms between flats in a block should also avoid bedrooms adjoining neighbouring living rooms, kitchens and bathrooms, as well as communal areas such as halls and stairs.

- 9.7 Built-in storage spaces are highly valued components within new homes. Lack of such spaces can lead to domestic clutter being stored on balconies, within hallways or other communal areas. New development should therefore ensure that there is sufficient provision within each home for the storage of domestic items such as vacuum cleaners, ironing boards and children's toys, commensurate with the likely needs of future occupiers. Further guidance on these standards is available in the SD&C SPD (para 2.2).

Entrances and windows

- 9.8 The entrance to residential buildings marks an important transition between public and private space. The main entrance can be an important part of a building's architectural expression providing a wider understanding of the building's function(s) when viewed from the public realm. Main entrances in new buildings should be clearly visible from the street, contributing to the overall legibility of the development, and should be fully accessible. In larger buildings, this may require greater height or more considered design elements to ensure that the proportion and scale of the entrance reflects the overall scale of the building.
- 9.9 Where building design seeks to complement that of neighbouring buildings, special attention should be paid to fenestration details. This includes consideration of the window proportions (horizontal or vertical emphasis), the relationship of the window with the surface of the building elevations (flush or set-back).

Active frontages

- 9.10 Active frontages, characterised by doors and windows, help to avoid blank walls facing the public realm and provide natural surveillance. Primary access to dwellings should be from the street wherever possible, and direct rather than communal entrances are preferred to support active frontages and contribute to the legibility of an area. Where communal entrances are required (for example access to stairs and lift lobbies) the entrances should be prominent, spacious to accommodate buggies and wheelchairs and have secure access for residents.

Principles

- **ensure new block layouts respond to the size and structure of blocks in the surrounding area**
- **all new developments should follow the Mayor's minimum space standards for new homes**
- **Ensure the design and layout of developments (including balconies, stacking of rooms, windows) minimise the potential for noise transfer between new homes and minimises overlooking.**
- **Fronts and backs of dwellings should be arranged appropriately to maximise active frontages onto streets**

10. Movement and accessibility

'Plans should protect and exploit opportunities for the use of sustainable transport modes for the movement of goods or people. Therefore, developments should be located and designed where practical to...create safe and secure layouts which minimise conflicts between traffic and cyclists or pedestrians, avoiding street clutter.....'(NPPF para 35)

Access

- 10.1 Successful residential neighbourhoods provide a high degree of both external connectivity and internal permeability therefore allowing people to go about their daily activities with ease.
- 10.2 In larger developments the access to and circulation through the development should integrate with and improve the existing movement patterns of the wider area. On larger developments, a network of well connected streets should be provided that offers a choice of routes with easy access to local amenities, open space, the public transport network and established routes.
- 10.3 Infill developments should pay particular attention to the way they link together the areas that surround the site to avoid creating isolated enclaves of development that are out of character in the locality. However, the need for permeability should still maintain safety, security and privacy. All access points should be clearly visible, routes into and through a development should minimise areas where the private activities of residents are visible to the public, safe to use, clearly defined and necessary, leading to places where people want to go.

Movement

- 10.4 Places with lower speed limits are generally safer and can provide a more pleasant living environment than streets with fast traffic. Streets that manage traffic speed by their design, for example through careful treatment of surfaces, pedestrian crossings and the arrangement of buildings, are normally favoured over physical traffic calming measures. Narrower streets can often be safer and help to avoid the appearance of a housing area which is dominated by cars rather than pedestrian movement. In some instances, it may not be necessary to separate pedestrian, vehicular and cycle routes. Refer to Department for Transport's Local Transport Note 1/12 - Shared Use Routes for Pedestrians and Cyclists (September 2012) providing advice on detailed design for shared uses.
- 10.5 Work on the highway is likely to require a Section 184 / 278 Agreement with the Council. This may enable improvements to be made to an adopted highway as part of the proposed development. These improvements include but are not limited to the formation of a new access or improvements to local highway infrastructure to accommodate the increase in expected traffic generated by the development. Should on-site roads and footways be proposed for adoption as public highway then a Section 38 Agreement will be required with the Council involved at the design stage to ensure relevant design criteria is met prior to construction. It is recommended that the developer discuss the requirements of any potential highway works with the Council at the earliest opportunity to confirm that the proposals will be of benefit to the general public

Legibility

- 10.5 Places should ‘make sense’ to the people who use them. The use of townscape features (e.g. gateways, nodes, landmarks, edges, views and vistas) is encouraged to give the development a clear identity and make the layout easy to understand for residents and visitors. Corner buildings and other easily identifiable visual markers are of particular importance for creating recognisable, understandable places. It is advisable to provide wayfinding signage to indicate safe routes to /from all key destinations

Consider all users

- 10.6 Streets should be designed as public spaces with the needs of all users considered. Well designed streets with safe, direct, convenient and clear pedestrian and cycle routes maximise the transport choices of residents, and can influence people to use more sustainable modes of travel. Residential layouts designed solely to meet the requirements of vehicular traffic are not acceptable. New routes and connections should provide integrated routes for pedestrians, cyclists and vehicular traffic.
- 10.7 Where segregated routes for pedestrians are provided, they should serve a clearly defined function and meet the criteria set out within the guidance document “Safer Places: the planning system and crime prevention”. Pedestrian and cycle routes should follow desire lines, in so far as possible, and be free from barriers except where necessary to prevent motorcycle access.

Principles

All developments:

- **should connect new and existing routes to create a network of well-connected streets which improve movement patterns in the wider area**
- **should ensure that design and layout is legible and is oriented around the needs of pedestrians, cyclists and connectivity to the public transport network**
- **that generate significant amounts of movement should be supported by a Transport Statement or Transport Assessment**
- **where new roads are proposed for adoption, involve the Council at an early stage in the design**
- **should refer to Table 3 in Section 4 of this SPD in order to provide safer and secured designs.**

11. Car parking, cycle storage and waste storage

‘Barnet’s Characterisation Study identified the severe impact of off-street car parking and consequent loss of front gardens on the dominant street typologies’. (Barnet Core Strategy, Para 10.7.1)

Car Parking

- 11.1 The location and provision of car parking is a key design issue. Car parking should not dominate or overburden residential areas, particularly the fronts of houses, or inconvenience pedestrians and cyclists.
- 11.2 The use of lighting, trees and planting and street furniture can help to better integrate parking into the overall scheme and wider streetscape. In-curtilage parking should be located close to the home to avoid inconvenience and increase natural surveillance. Large, isolated car parks should be avoided. Refer to para 7.12 on lighting schemes and ways in which light pollution can be mitigated.
- 11.3 Whilst parking will normally be provided within private areas, access to parking should be convenient for residents. Limited additional vehicular parking may be appropriate and will be considered on a case-by-case basis. Streets should be designed not to be dominated by cars. Parking facilities should also be considered for powered two-wheeler vehicles that will be considered on a case-by-case basis
- 11.4 The Local Plan's approach to parking management is set out at Section 18.8 of the Development Management Policies document. Developers should follow Barnet's residential car parking standards as set out in Policy DM17 in order to determine provision in new development. Refer to Table 2.8 of the SD&C SPD for the provision of suitable electrical charging point. Inclusive mobility guidance published by Department for Transport sets out parking standards for disabled drivers.

Cycle storage

- 11.5 The design and layout of new residential development should take account of the needs of cyclists through the provision of safe, accessible and secure cycle parking. In accordance with the cycle parking requirements set out in the London Plan (Table 6.3).
- 11.6 Barnet's approach to cycle parking is set out at Section 18.8 of the Development Management Policies document Cycle parking facilities should be located in safe, well-lit and overlooked areas that are in close proximity to main building entrances. The facilities should provide weather protected parking and be built with durable, high quality materials that are resistant to wear and age well.
- 11.7 Well-designed cycle storage can encourage people to cycle and avoid other areas in the home, such as balconies and hallways, being inappropriately used to store cycles. Developers should aim to make cycle storage as convenient as access to car parking to encourage cycling as a sustainable mode of transport. Detailed information on technical aspects is provided in the Sustainable Design and Construction SPD (section 2.4)
- 11.8 New flatted development should provide some space either inside the building in a cycle store-room or provide a separate, secure and accessible bike shed within the overall development. Parking for bicycles should be provided in all new development. Major residential, high density developments should provide secure on site spaces for each unit. Mixed use town centre development should provide secure off street space where possible.

Waste and recycling storage

- 11.9 The design and layout of residential development should normally make satisfactory arrangements for the storage and collection of recycling and waste. The arrangements should comply with the Sustainable Design and Construction SPD (section 2.12) and the councils’ “Information for developers and architects – provision of domestic and organic waste services, and recycling facilities”.
- 11.10 Waste and recycling storage can cause a nuisance to neighbours and future occupiers, by reason of odour and noise, and can be visually intrusive in the streetscene. In meeting the council’s requirements the amenity of residents, the appearance of the area, as well as the ease of access should be considered. Waste and recycling storage areas should be integrated within the building or provided on-site and screened within an enclosure or by landscaping avoiding garden areas in front of dwellings.
- 11.11 Details of refuse storage and management will normally need to be addressed as part of the planning application. Poorly designed, intrusive or inadequately sized facilities give rise to adverse visual impact and will not be acceptable.
- 11.12 In flatted developments, waste and recycling storage should at an early stage be sensitively designed and located. Careful consideration should be given to access to waste disposal and recycling facilities, particularly for residents on upper floors. Storage areas should be in a position mutually convenient and easily accessible for both residents and waste and recycling collection crews.

Principles

Developments should:

- ensure adequate car and cycle parking is incorporated
- consider access, convenience, safety and security when designing cycle storage, waste and recycling storage.
- details of refuse storage and management should be addressed as part of the planning application

12. Design of basements

‘Most development in Barnet involves the replacement, extension or conversion of existing buildings so taking account of context and local character is particularly important. We will therefore expect the design of new buildings and places to respond to the local area and its defining characteristics and reinforce or create local distinctiveness.’ (Barnet’s Core Strategy para 10.5.12)

- 12.1 This section addresses design aspects of basements within new residential development. For existing residential developments, guidelines on basement extensions are set out in Part Three, section 14.44 of this SPD. Further guidance on technical requirements, including the links to the surface water management plan, is set out in Barnet’s Sustainable Design and Construction SPD (section 2.15.3 and table 2.17).
- 12.2 For new residential development, basements should generally be limited to the proposed footprint and volume of the house or building. In larger buildings with extensive plots it may be possible to extend under part of the rear garden. It will be necessary to ensure that a mature garden can be established and maintained above the basement and details of soil and drainage will normally be required at the time of submitting a planning application.
- 12.3 Basements used for residential purposes are considered ‘highly vulnerable’ in the flood risk vulnerability classification (as set out in the Technical Guidance to the NPPF and will not normally be permitted in Flood Zone 3. Basements used for residential may only be allowed in Flood Zone 2 following the application of the Sequential Test and Exception Test.
- 12.4 Lightwells or skylights should be located away from the property boundary to enable a planted boundary to be maintained. They should be proportionate to the building they relate to. Open lightwells and sunken terraces will be resisted.
- 12.5 Illumination and light-spill from a lightwell can harm the appearance of a garden setting and cause nuisance to neighbouring properties. This will be taken into account when planning applications are considered. They should not harm any nearby trees, restrict future planting and mature development of trees typical of the area. It should be possible to establish and maintain hedges following construction of a basement. Forecourt parking arrangements should be considered carefully as light to basement windows can be severely restricted.

Principles

New development:

- **which includes visible external manifestations of a basement should pay special attention to the building they relate to and protect the character and appearance of the local and wider area and the setting of the individual development they form part of**
- **should ensure that the basement development does not harm the established garden, open area, nearby trees and that no adverse impact is caused to the amenity of neighbouring properties.**

13. Residential development within town centres

‘Encouraging greater housing development within or on the edge of some of Barnet’s town centres is an option that allows mixed uses which add vibrancy and greater all round activity. This can provide attractive locations for people who want to live close to services, jobs and public transport, for example, older people, single people and couples. (Barnet’s Core Strategy para 8.2.2)

- 13.1 The design principles set out in Table 3 of this SPD will apply to residential developments within or outside town centres. However, given the location, size and type of residential developments within town centres, different planning and building parameters may be applicable.
- 13.2 Encouraging more people to live in town and local centres for easy access to shops and services, increases the viability of these centres and reduces the need to travel by car as these centres generally have good transport links and there are increased opportunities for walking and cycling. Opportunities for housing as part of a mixed use development are largely focused on Barnet's town centres. For town centre residential accommodation the standards applied elsewhere in the borough (for example, in relation to car parking and amenity space) should be considered in line with Policies DM11 and DM17 and will be assessed on a case by case basis.
- 13.3 Barnet's town centres are considered to offer opportunities for residential growth as part of mixed use development. All mixed use development should:
- be of a high quality design
 - ensure that the residential and other land uses are appropriately separated to protect the amenity of all occupiers of the site, with separate waste and recycling storage provision
 - comply with the standards within this SPD for residential development and the Sustainable Design and Construction SPD.
- 13.4 Town centres typically have an urban identity, and are often characterised by development which forms a continuous building frontage directly abutting the pavement edge, with service areas at the rear of the buildings. Major considerations will include the continuity of building frontage, plot widths, residential access and servicing arrangements, the treatment of return frontages as well as the transition between the urban and suburban development pattern.
- 13.5 In the case of higher density developments where less distance is provided (as compared to the distance highlighted in Table 2), applicants will be asked to include innovative design solutions to avoid overlooking such as angled windows, careful choice of window locations, obscured glazing, use of level changes, staggering of windows, screening and single aspects dwellings.
- 13.6 The design and provision of private amenity space is particularly important in flatted schemes within Town centres, but more flexibility on provision may be given when it is difficult to provide amenity space. For further details on the provision of outdoor amenity spaces, refer to section 8 of this SPD.
- 13.7 The upper storeys of shops and other commercial buildings offer opportunity for new homes. Living above shops and commercial buildings can increase the vitality of an area and provide surveillance outside of normal business hours. Additional considerations include:
- The amenity of residents and occupiers, or of the surrounding area
 - Sound proofing measures for the residential units and internal layout considerations
- 13.8 The Sustainable Design and Construction SPD (section 2.14) provides further guidance and requirements on how to reduce disturbance from noise.

Principles

- ensure the size and design of new residential development within town centres relates to its setting, density and character
- encourage innovative designs and ensure required standards are used appropriately.
- for town centre residential accommodation the standards applied elsewhere in the borough (for example, in relation to car parking and amenity space) may be relaxed in line with Policy DM14 and will be considered on a case by case basis.

PART 3

Design Guidance for Existing Residential Development in Barnet

14. Extensions to houses

'Most development in Barnet involves the replacement, extension or conversion of existing buildings so taking account of context and local character is particularly important. We will therefore expect the design of new buildings and places to respond to the local area and its defining characteristics and reinforce or create local distinctiveness.' (Barnet Core Strategy para 10.5.12)

- 14.1 This section revises and updates Barnet's Design Guidance Note 5 and sets out how the council considers planning applications for extensions to houses including semi-detached, detached and terraced houses as well as properties which have been

converted into flats, although the overarching principles can be applied to all residential properties.

- 14.2 Extensions to houses both individually and cumulatively can have a profound effect on the appearance of an area and on the amenities enjoyed by the occupiers of adjoining properties. In general, extensions should reflect the design of the original building, whilst having regard to the character of the area and the residential amenity enjoyed by neighbours. This means ensuring that the extension does not significantly impact on people’s enjoyment of their own home or garden.
- 14.3 Not all houses can be extended. This may be due to lack of space or their position or design will mean any extension would harm the street scene or local amenity. In addition, there is a limit to how much most houses can be extended. The cumulative effect of extensions and their impact on the appearance of an area should also be taken into account. This means that proposed additions, which meet all the guidelines included in this SPD, may still be considered unacceptable and be refused planning permission.

Amenity

- 14.4 Extensions to properties should not be overbearing or unduly obtrusive and care should be taken to ensure they do not result in harmful:
- loss of privacy by overlooking adjoining properties
 - loss of light or overshadowing of adjoining properties, particularly loss of light to main windows serving principal rooms such as living or dining rooms
 - loss of outlook from adjoining properties
 - sense of enclosure or overbearing impact on adjoining properties
 - loss of garden, landscaping or open space, which contributes to local amenity
 - loss of parking space that is desirable to retain
- 14.5 The Environment Agency has ‘flood risk standing advice’ available on their website for householder and other extensions in Flood Zones 2 and 3; this advice should not be applied if an additional dwelling is being created (e.g. a self-contained annex).
- 14.6 Whilst there is a judgement on what constitutes a harmful, overbearing or obtrusive extension (see Figure 1), it’s advisable to contact the council duty planner for an early advice.
- 14.7 An extension at the rear of a property may affect the applicant / householder’s amenities by restricting natural light to existing rooms requiring, artificial light to be used for much of the day which will cost more in energy, be less sustainable and affect the enjoyment of the accommodation.

Harmony

- 14.8 Proposed extensions should be consistent with the form, scale and architectural style of the original building, particularly where it is a period or suburban property.
- 14.9 Consistency with the original type of a building can be achieved by:
- Respecting the proportions of the existing house
 - Using an appropriate roof form

- Matching materials and details
- Use of innovative design that can add and improve the building outlook
- Matching the window style, proportions and position
- Reflecting the character of the original house.

Whichever type of design is proposed, the following rules should apply:

- The extension should normally be subordinate to the original house
- The extension should respect the original building and should not be overly-dominant
- The height of the extension should normally be lower than the height of the original building. For example, this can usually be achieved for a two-storey side extension by stepping down the roofline and setting back the front building line (see Figure 2).



Figure 1: Overshadowing, overlooking and loss of outlook

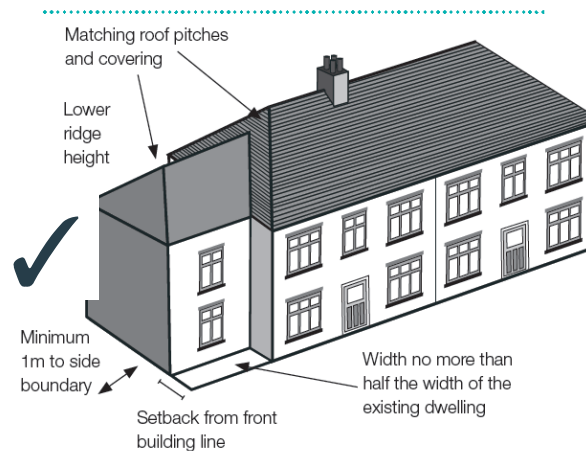

Figure 2: Subordinate approach

Materials and details

- 14.10 External finishes, materials and architectural features affect the appearance of the extension. It is important to match the brickwork and roofing materials of the existing house in terms of colour, type and size. The brick bond and mortar joints should also be copied. The design, proportions and position of joinery details, windows and doors should reflect those of the original building to ensure the details of the new extension are sympathetically in-keeping and do not detract from the area's general character.
- 14.11 Windows on extensions should normally match those on the existing house, in terms of their design, material and proportions. Where necessary, they should also be recessed to match the original windows. Where a hierarchy exists (i.e. they reduce in size the higher up the house they are) those windows on upper floors will often need to be slightly smaller than those on the floors below. Original bay windows are important features which should not be enlarged or altered significantly, to avoid having an adverse effect on the appearance of the house.
- 14.12 Where a flat roof is appropriate on a single storey extension (and in many cases pitched roofs are a better design), the roof should relate to any existing horizontal elements such as string courses or to the line of change between materials e.g. brick to render or tile hanging. Brick on edge coping is usually more satisfactory than a timber fascia board. Flat roofs should not normally be used as balconies and should only be

accessed for maintenance purposes as nuisance and loss of privacy to immediate neighbours may result in overlooking into their amenity space. In such cases conditions will normally be applied to the planning consent.

Fitting into the street

14.13 If there is a consistent and coherent architectural character, the extension should not detract from it. The extension should sit comfortably with the main building and with neighbouring houses by:

- Taking account of the group value, character and established form of development along the street
- Using a design and facing materials which blend in with the character and appearance of the existing house
- Taking account of changes in levels between properties, gardens and the road
- Taking account of the angle and position of the house. This may increase the visual effect of the extension in the street scene



Figure 3: Maintain gaps between houses with subordinate extensions

- complementing the roof form of the original house and the surrounding area (see Figure 3)
- Leaving enough space between houses to make sure they appear well separated
- Avoiding protruding beyond prominent building lines
- Glimpsed views between buildings, which in allowing greenery and sky to be seen from the road contributes to the character of the area
- Take account of existing features along the boundary, for example, outbuildings, fences, walls and trees
- Making sure the garden remains capable of providing adequate amenity space for enjoyment at the property.

Side extensions

14.14 Side extensions to existing buildings can be unacceptably prominent features in the street scene as shown by Figure 4. Where gaps between houses are a common feature of a street, then proposals which close such gaps or create a terracing effect by bringing buildings too close together are likely to be rejected.

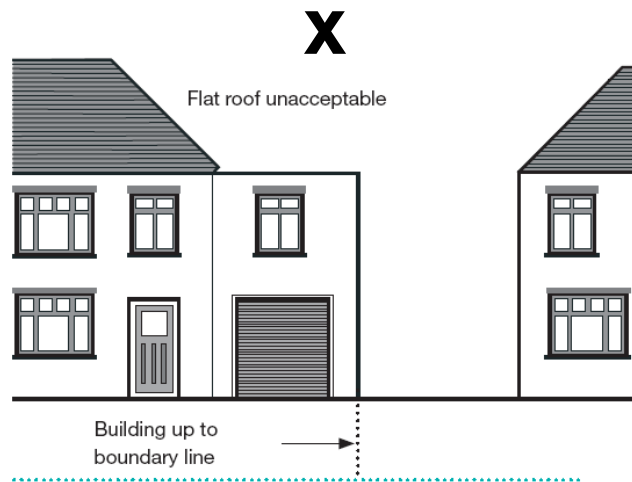

Figure 4: An inappropriate side extension on a semi-detached house

- 14.15 Side extensions should not be more than half the width of the original house. In addition, the setting back of the front wall of side extensions from the front building line can help to reduce the visual impact on the street scene. First floor side extensions should normally be set back 1 metre from the front main wall of the existing house. Figure 5 shows a subordinate side extension.

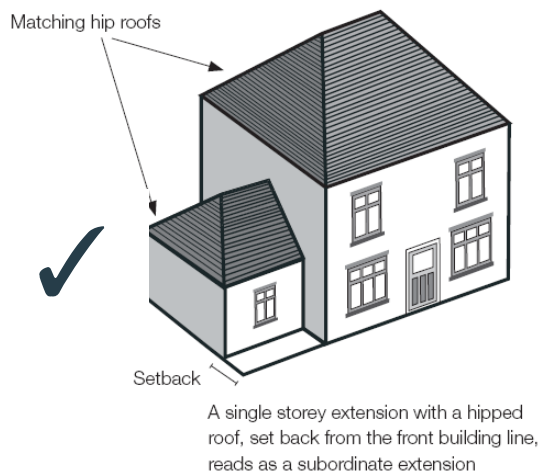

Figure 5: A subordinate single storey extension

- 14.16 Pitched roofs help extensions fit in with the street and may be required for single storey extensions. Pitched roofs, following the same pitch as the existing roof, will normally be needed for two storey extensions and be set down at least 0.5 metre from the ridge of the main roof. Side windows or other detailing can help improve the appearance of a flank wall. Figure 6 shows an inappropriate side extension to a detached house. With a flat roof and lack of setback it is too dominant.
- 14.17 In order to reduce the visual impact of two storey or first floor side extensions, there should normally be a minimum gap of 2 metres between the flank walls of properties at first floor level (i.e. a minimum gap of 1m between the boundary and the extension at first floor level for most two storey extensions).

- 14.18 A larger gap may be required if the adjoining property would in any way be demonstrably harmed. Where possible, an existing direct access to a rear garden should be retained.

The flat roof is unacceptable, and the extension has not been set back from the front building line and is too dominant. The windows and garage door detract from the original property.

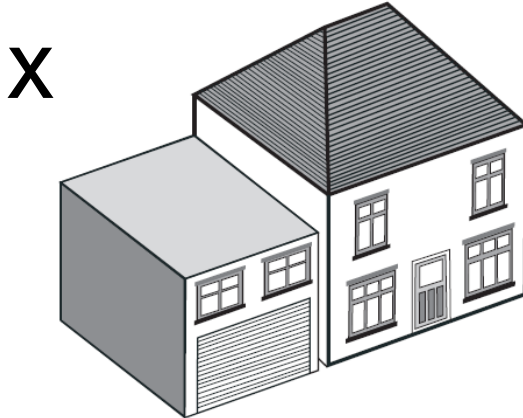

Figure 6: An inappropriate side extension on a detached house

- 14.19 Extensions on corner sites will be particularly open to public view. First floor extensions on corner sites should not project beyond the building line of the adjoining road (see Figure 7).

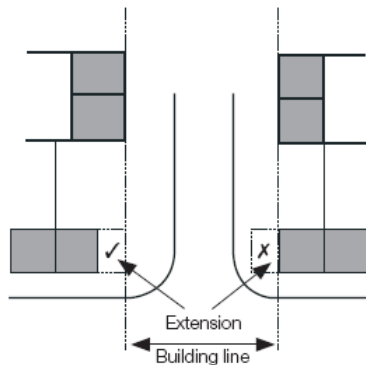

Figure 7: Do not protrude past prominent corners

- 14.20 Side extensions should ensure that the visual and residential amenities of neighbouring properties are not significantly affected.

Rear extensions

- 14.21 The depth of a single storey rear extension, normally considered acceptable for terraced properties is 3 metres, for semi-detached properties it is 3.5 metres, and detached property is 4 metres.

- 14.22 Single storey rear extensions to the original house, need to ensure that:

- the depth and/or height of the extension does not cause a significant sense of enclosure, or loss of outlook from, or light to, principal windows of habitable rooms of neighbouring properties
- they do not look too bulky and prominent compared to the size of the main building and garden to which they relate
- if the garden space is in breach of amenity standards then application will normally be refused
- in addition, if the adjoining house is at a lower level or has a rear building line set back from your rear building line, the depth of the proposed extension may need to be reduced in order to protect amenity of your neighbour.

14.23 However, where there is significant harm to neighbours or residential amenities, deeper extensions than that of neighbour's house would be inappropriate. In such cases each proposal will be considered on its own individual merits. Figure 8 shows an over-sized two storey rear extension. Two storey rear extensions which are closer than 2 metres to a neighbouring boundary and project more than 3 metres in depth are not normally considered acceptable. This is because they can be too bulky and dominant, and have a detrimental effect on the amenities of neighbours.

14.24 Two storey rear extensions need to ensure they do not lead to:

- loss of light to, and outlook from, windows and glazed doors positioned close to the extension
- unacceptable sense of enclosure to house and garden
- overbearing impact
- harm to the character or appearance of the property and area.

Two storey rear extensions should not create an unacceptable sense of enclosure or have an overbearing impact on the adjoining house or garden

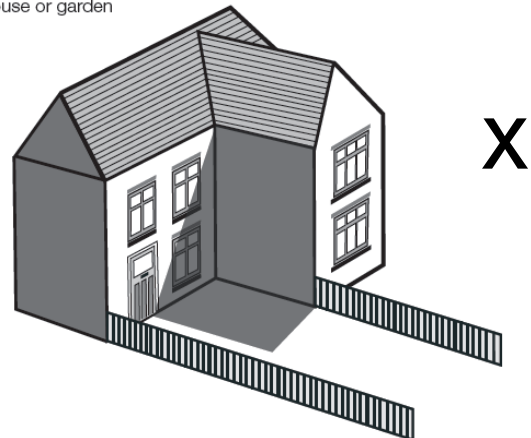

Figure 8: An over-sized two storey rear extension

14.25 On widely spaced semi-detached or detached houses, there may be more scope for larger rear extensions. However, the principles of good design set out in Table 3 of this SPD still apply.

14.26 Flat roofs should not normally be used as balconies as loss of privacy to immediate neighbours almost always results. This applies to side as well as rear extensions. Flat roofs on two storey rear extensions are not normally acceptable because they do not relate sympathetically to the house. Refer to overlooking issues and conditions listed in para 14.11.

14.27 Proposed extensions on properties located within a designated conservation area will need to ensure that they preserve or enhance the character and appearance of the conservation area.

Front extensions

- 14.28 Large, front extensions will not normally be permitted because of their effect on the street scene and character of the area in general.
- 14.29 Where it is considered that a building may reasonably be extended forward (for example, on occasion detached houses in low density areas or in roads with irregular building lines), the following principles should be observed:
- the new roof should normally reflect the roof form of the existing house (e.g. pitched with tiles to match)
 - front extensions should fit in with the architectural style of the house
 - care should be taken to ensure that front extensions have regard to, and do not conflict with, existing architectural features such as bay windows
 - windows should be positioned where they do not have a harmful effect on the amenities of neighbouring properties.
 - porches should be designed in accordance with the requirements listed in section 14.51-55 of this SPD.

Dormer roof extensions

- 14.30 Additional, usable space can sometimes be created by converting roof space, providing this is carried out sympathetically. This often involves the formation of dormer windows or the insertion of roof lights. Many houses in Barnet have roofs that are too small for conversion, or in some cases, dormer windows or roof lights may be out of keeping with the character of the area.
- 14.31 A dormer roof extension is a vertical window or opening in a sloping roof, having its own roof, either flat, pitched or curved. Such extensions can have a significant effect on the appearance of a house and their design needs careful consideration.
- 14.32 Dormers on the front of semi-detached or terraced houses will not generally be acceptable, due to their unbalancing effect on adjoining houses and the general street scene. Any exceptions are extremely limited and usually only where original front dormer extensions exist.
- 14.33 The following points should be considered for dormer roof extensions:
- *Design* - should reflect style and proportion of windows on the existing house. Dormers may have flat, gabled, hipped or curved roofs and subject to the criteria on position, should normally align with the windows below.

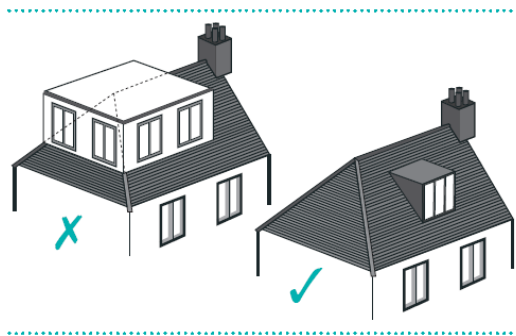

Figure 9: Size and scale of dormer windows. Dormers should be of an appropriate size and position

- *Position* - Dormer roof extensions should not overlap or wrap around the hips (see Figure 9) or rise above the ridge. Adequate roof slope above and below the dormer is required on semi-detached and terraced properties, the dormer extension should be set in at least 1 metre from the party wall, flank wall or chimney stack. In smaller terraced houses where due to internal physical constraints dormers that are set in less than 1 metre will be taken into account providing such constraints and any minimum Building Regulation or fire regulation requirements are clearly and robustly demonstrated.
- *Scale* - Dormer roof extensions should normally be subordinate features on the roof and should not occupy more than half the width or half the depth of the roof slope. Dormers which wrap around the hips will not normally be considered acceptable (see Figure 9).
- *Proportion* - To retain the balance of the house, the dormer roof extension should not normally be wider than the window below it and the dormer cheeks kept as narrow as possible (see Figure 10). For smaller enclosed houses, such as terraces consideration and allowance will be given to internal workable space and Building Regulation requirements for wider roof extensions. On side dormer extensions, where there is a requirement to provide adequate headroom for stairs, the extension should still be set away from the ridge and clear of the hips (see Figure 10).
- *Overlooking* - Care should be taken in the design and location of new dormers, including side dormers to minimize overlooking
- *Materials* - The window materials and design should be in keeping with those on the rest of the house. The dormer cheeks should be finished with lead, tiles, slates or other traditional materials, and the top of flat roofed dormers should be finished with lead or zinc. The use of roofing felt for the roof, cheeks or face of the dormer should be avoided.

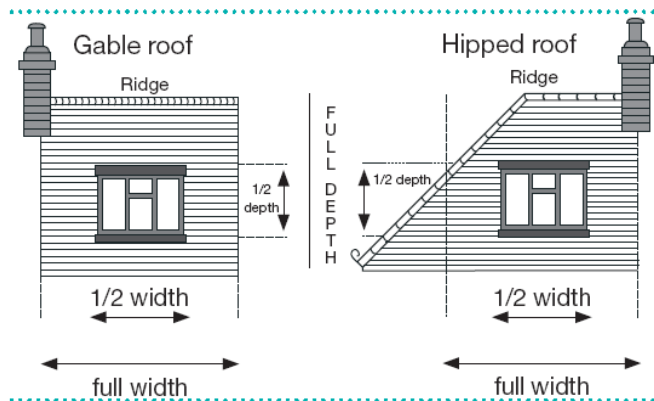

Figure 10: Rear dormer windows of an appropriate scale

- Roofs - Dormer roofs should be sympathetic to the main roof of the house. For example, pitched roofs to dormers should be hipped at the same angle as the main roof (see Figure 11).

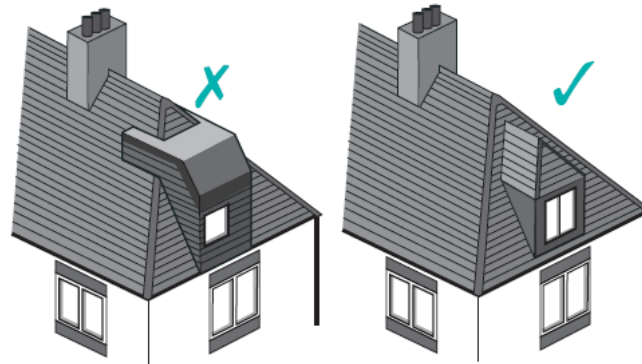

Figure 11: Relationship to existing roof design and bulk is important

Large roof extensions

14.34 Consideration will be given to whether or not gable end extensions are a characteristic feature of the street and wider area.

14.35 Proposed hip to gable roof extensions need to take into account the following criteria:

- The gable should not unbalance a pair of semi-detached houses or a short terrace
- The gable should not reduce the degree of visual separation between houses or glimpsed views from the street
- The gable should not form an overbearing wall facing a street, neighbouring garden or other public place
- The gable should not appear out of character within the streetscape

Roof lights

14.36 Roof lights should be carefully positioned in order not to impact detrimentally or disfigure the appearance of a building, particularly where they are not a characteristic feature in the street. On front roof slopes roof lights should be of the ‘conservation type’ i.e. fitting flush with the roof slope and they should not dominate the roof in terms of their number. It is preferable to position them on rear roof slopes (see Figure 12)

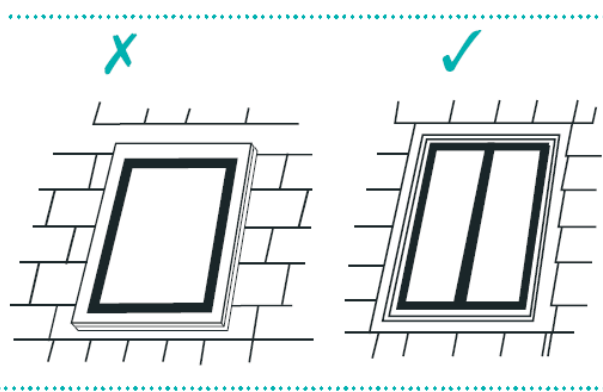

Figure 12: Flush fitting ‘conservation’ style rooflights sit more comfortably within roof slopes

Detached ancillary buildings in front and back gardens

14.37 All developments should protect and enhance the gardens at residential properties. The natural features and spaciousness of gardens make an important contribution to Barnet’s distinctiveness as well as climate change mitigation in terms of urban cooling and management of surface water. Detached buildings in gardens can therefore have a significant impact on local character, amenity and flood risk in gardens as well as its surrounding areas.

Front garden buildings

14.38 Front gardens walls, fencing and railings should be sympathetic to the character of the building and garden and normally no higher than 1 metre. Original railings should be retained where possible.

14.39 Detached buildings are not normally acceptable at the front of terraced or semi-detached houses because of their dominant impact on the street scene. On detached houses, they will only be considered acceptable where detached buildings in front gardens form part of the existing character of the street. For instance, where detached buildings were built as part of the original form and layout of an estate.

Back garden buildings

- 14.40 In general, rear garden walls and fences should not exceed 2 metres to protect views and daylight. The same principles apply to the design of back garden buildings as to rear extensions:
- they should not unduly over-shadow neighbouring properties
 - they should not be too large or significantly reduce the size of a garden to become out of character with the area
 - they should not unduly affect outlook from an adjoining property's habitable rooms or principal garden areas
 - their design and materials should be in harmony with the surrounding area.
- 14.41 Proposals should consider location of garden buildings such as sheds and greenhouses so that they minimise the impact on neighbouring properties. Garden buildings should be located to the rear of properties. The building materials used should respect the existing buildings and the overall character of the area. Garden buildings should minimise any impact on trees.

Basement extensions

- 14.42 The council seeks to ensure that basement development does not harm the established architectural character of buildings and surrounding areas, including gardens and nearby trees, and that no adverse impact is caused to the amenity of neighbouring properties.
- 14.43 Often with basement development, the only visual manifestations are light wells and skylights, with the bulk of the development concealed wholly underground and away from any public view.
- 14.44 The council will normally allow single floor basement extensions which do not project further than 3 metres from the rear wall of a house or more than half its width beyond each side elevation. If you intend to carry out work to an existing wall or structure which is shared with another property, build a free-standing wall or a wall up to or astride the boundary with a neighbouring property, or excavate near a neighbouring building, then the neighbours should be notified under the provisions of the Party Wall Act 1996. It should be noted that issues that relate to boundary disputes and land ownership are not planning matters. Similarly, issues related to foundations and movements are not planning but Building Control matters, therefore relevant departments should be contacted for any further guidance.
- 14.45 The following points should be considered for basement extensions:
- Nearby trees roots on or adjoining the site should not be damaged.
 - Not more than 50% of the amenity space (garden or front court yard) should be removed.
 - Neighbouring ground water conditions should not be adversely affected.
 - Any exposed area of basement should be subordinate to the property being extended and respect its original design and proportions. The length of any visible basement wall should not dominate a property nor extend its full width. In number, form, scale and panel size, basement windows should relate to the façade above.

Windows should be aligned to any openings at the higher level and be of a size that is clearly subordinate to these so as to respect the character of the original building.

- Light-wells at the front need to appear as discreet interventions that do not harm the character or appearance of the building and its frontage. In situations where light-wells are not part of the established street scene, the nature of the front garden will help to determine their suitability. Where the depth of a front garden is sufficient, basement light-wells are more easily concealed by landscaping and boundary treatments providing a visual buffer from the street. In such circumstances light-wells that are sensitively designed may be acceptable, subject to other design requirements.
- Railings, grilles and other light-well treatments should avoid creating visual clutter and detracting from an existing front boundary wall, or obscuring front windows. This is particularly important in shallow gardens where front light-wells should be secured by a grille which sits flush with the natural ground level, rather than with the use of railings. Railings will be considered acceptable where they form part of the established street scene, or would not cause harm to the appearance of the property and neighbouring area.
- All rooms within a basement should be able to function properly for the purpose intended. They should be of an adequate size and shape and receive natural lighting and ventilation. All habitable rooms within basement accommodation should have minimum headroom of 2.5 metres.
- Forecourt parking arrangements should be considered carefully as light to basement windows can be severely restricted.

Annexes to dwellings

- 14.46 Proposals to build an annex will be considered on the individual merits of the scheme but as with any other extension they should comply with the relevant design parameters outlined in this SPD.
- 14.47 An annex must not have a separate entrance or staircase and should be internally connected to the rest of the house and should not include a separate kitchen. It must remain ancillary to the main house at all times and this should be conditioned.

Extent of extensions in Green Belt/ Metropolitan Open Land

- 14.48 Within Barnet's Green Belt /MOL, extensions should not result in disproportionate additions over and above the size of the original house. An "original dwelling" as referred to in the policy is that as existed on the 1st July 1948, or as originally built if constructed after that date. As a guiding principle the volume of the original dwelling should not be increased by more than 25% by external measurement in order to protect openness. The cumulative effects of previous extensions will be taken into account. Proposed demolitions can be deducted in calculations if they are an integral part of the dwelling.
- 14.49 There may be cases where more than a 25% increase is justified to produce a better design solution but there may also be cases where less than 25% is appropriate, to avoid a disproportionate extension to a dwelling or where the site is especially prominent.

14.50 The calculations will include unused permitted development rights and any extant consents to build accordingly. The exception to this will be when the applicant agrees to the extinguishment of unimplemented permissions or parts thereof. In all cases the council will require a detailed survey which shows all buildings within the curtilage of a site and the details of its planning history. The use of excessive extensions to create additional units may indicate an overdevelopment of the site and will be unacceptable. Extensions to houses adjacent to Green Belt/MOL should respect the character of their surroundings and the visual amenity of these areas.

Porches and canopies

14.51 This section replaces Barnet’s Design Guidance Note 11 on Porches. Further information is also available on the Planning Portal website.

14.52 As shown below a porch is built around an external door giving access to the building. A porch is not necessarily the same as a front or side extension. A front porch on a house is “permitted development” provided that:

- it is not added to a flat, apartment or boarding house;
- the ground area (measured externally) does not exceed 3 square metres;
- the height does not exceed 3 metres above ground level;
- no part of the porch is closer than 2 metres to any highway;
- there is no condition on a previous planning permission for the property which takes away your permitted development rights. This is most common on new houses;
- No part of the porch (including the foundations) will encroach on or over the adjacent neighbour’s property;
- the house is not a listed building or within a conservation area. In these cases special considerations apply.

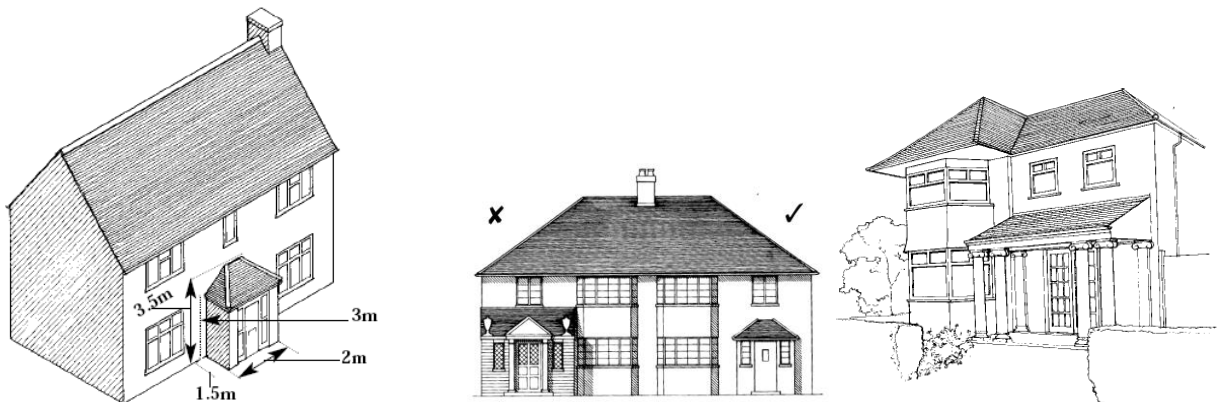

Picture: please note that in some cases these maximum sizes may be too large to achieve visual balance with your house.

14.53 It is natural for owners to want to improve and extend their properties, but the extensions need to be carefully designed. A properly designed porch can have a positive effect on the area. In some cases depending upon the location, size, type,

either larger or smaller porches may be appropriate. The porch roof should reflect the roof style of the existing house. As shown below the material, shape and style of existing doors and windows should be matched to create an overall balance to the design.



Picture: Examples of angled porches which blend in with the bay windows.

14.54 Where a porch is on the front elevation, special care should be taken that it does not spoil the appearance of the property and street as well as the outlook of neighbouring houses. Adding undue canopies can be unsightly as it is likely to protrude too far and dominate the front of the house. As houses differ in size and style, sometimes it is not possible to add a porch to a house.

14.55 In case a carport is being constructed, make sure it is well designed as it can often detract from the design of the property and the whole of the street. It is important that the materials used are sympathetic to the original house. In addition, as with garages, it is important there is adequate distance to park a car outside the carport and still remain clear of the highway or footpath.

Conversion of garages to habitable accommodation

14.56 The conversion of a garage to habitable accommodation (used for living/sleeping) may require planning permission. Depending on when the garage was originally granted consent, a condition on the consent may restrict its usage i.e. for car parking. In such cases planning permission is required to convert the space. The council will take into account the off-street parking available and the appropriateness of any external alterations i.e. changing the appearance of the garage elevation to a wall and a window.

14.57 Planning permission is also required for any proposal that involves extending the garage wall to create a bay window or extending beyond the front most part of the house. Design principles listed in Table 3 will still apply.

Principles and Further Guidance

Ensure:

- extensions reflect the design of the original building, whilst having regard to the character and appearance of the area
- the design of the extensions/ houses result in subordinate additions to the building they relate to and respect its existing architectural features, materials, settings, local character and wider context

- **proposed extensions, outdoor buildings and porches do not cause undue harm to the street, are not overbearing, intrusive, cause overshadowing or undue harm to the amenity of neighbouring occupiers and users**
- **all development proposals should protect and enhance residential gardens (side, front and back). Garden walls, fences, railings should be sympathetic to its local character and within required standards**
- **basement extension do not harm the established architectural character of buildings and surrounding areas, including gardens and nearby trees and that no adverse impact is caused to the amenity of occupiers, users and neighbouring properties**
- **extensions to houses adjacent to / within the Green Belt and MOL's should respect the character of its surroundings and the visual amenity of those areas.**

15. Conversions

‘The conversion of existing dwellings into flats can have a cumulative effect that is damaging to the quality of the environment and detracts from the character of established residential areas. Conversions may be appropriate in certain types of property or street particularly where they are highly accessible. However, even in such locations they can harm the character of areas by changing external appearance and increasing activity. Such activity can often involve more people movements, increased car movements and parking stress, more rubbish to be collected and more deliveries’. (Barnet Development Management Policies, para 2.8.1)

- 15.1 This section revises and updates Barnet’s Design Guidance Note 7 on conversions. The council’s approach as set out in the Local Plan is that the conversion of dwellings into flats in roads characterised by houses will not normally be appropriate. Therefore, this section of the SPD sets out how the council considers applications for the conversion of single family homes into two or more self-contained units including Housing in Multiple Occupation (HMOs).
- 15.2 The residential suburbs of Barnet have strong local character and streetscapes. Much of that character is derived from housing developed in the 1920s and 1930s with coherence and uniformity giving a sense of place to the suburbs. Therefore, for example when conversions seek new exterior alterations, such as replacement windows, doors or porches, these should reflect the prevailing local character and enhance, not disrupt the streetscape. Conversions in appropriate locations should not have any detrimental effect; they should not raise privacy issues, parking problems or have adverse effects on residential amenity.
- 15.3 Barnet’s approach to conversions as set out in Policy DM01 is to minimise their impact on the local environment and to ensure that occupiers of both new and existing units enjoy a high standard of amenity. Whether or not a conversion is acceptable in principle will depend on the character of both the house and the street.
- 15.4 The conversion of existing dwellings into flats can have a cumulative impact on environmental quality and the character of established residential areas. Conversions may be appropriate in certain types of property or street particularly where they are highly accessible. However, even in such locations they can harm the character of areas by changing external appearance and increasing activity. Such activity can often involve more people movements, increased car movements and parking stress, more rubbish to be collected and more deliveries.
- 15.5 Conversions generate extra movement of people and vehicles and the alterations required to accommodate such a use can impact upon the character and appearance of a locality. Conversion proposals are therefore likely to be resisted in areas of low density housing where predominantly there are single family occupation houses and where the external alterations would impact on the appearance of the local area (e.g. hardstanding for a parking space and refuse storage areas).
- 15.6 Where the conversion of a single family home into a small HMO or subdivision into flats is proposed the following should all be considered:
- The property should be large enough to be converted without the need for substantial additional extensions and
 - There should normally be access to the rear garden for all flats and,

- There should be adequate space off street to meet parking standards set out in DM17 and.
- There should be adequate space to provide suitable refuse storage in line with council guidance for architects and .
- Unit sizes should conform with the London Plan’s minimum space standards set out in Appendix 2 of this SPD or for HMO the Councils adopted Housing Standards⁴.

- 15.7 Flat conversions should aim to meet the outdoor amenity space standards set out in the SD&C SPD. The majority of converted dwellings have access to a garden, most likely in the form of a single or subdivision of an existing garden into private garden areas. This is usually split so that the garden area nearest the house is allocated for the sole use of the ground floor flat and the sub division furthest away from the house allocated for the sole use of the upstairs flat(s).
- 15.8 Front gardens are not considered to be appropriate as amenity space due to lack of privacy. Ground floor dwellings in flatted schemes can provide direct access to a private garden space leading to a private communal space beyond.
- 15.9 In circumstances where the building has no original or traditional features of merit, the design of any conversion to reflect the vernacular character and appearance of other buildings in the locality should be taken into account. Proposals should therefore have regard to the design and layout principles set out in Table 3 of this SPD.

Houses in Multiple Occupation

- 15.10 A small House in Multiple Occupation (HMO) is a dwelling in which three to six unrelated people (separate householders; unrelated to each other) share communal facilities such as bathrooms, kitchens and living rooms. From 29 May 2016 an Article 4 Direction was introduced to remove the permitted development right to convert a dwelling house (Use Class C4) into a small HMO (Use Class C4). Larger HMO are properties occupied by more than 6 unrelated individuals who share basic amenities such as a kitchen or bathroom facilities. They are classified as ‘sui generis’ (a use like no other) and always require planning permission. Policy DM09 of the Local Plan explains Barnet’s policy on Houses in Multiple Occupation. HMO’s may require licensing under the Housing Act and Environmental Health Act. Advice on this should be sought from Barnet’s Environment and Licensing services.

Principles of Good Design

- 15.11 If the principle of conversion is considered acceptable for a particular property, then the following detailed design principles should be taken into account:

1. External appearance

- 15.12 A good conversion should result in the minimum alteration to the external appearance of the house. Particular attention should be paid to the following points:

⁴ Barnet Council’s adopted HMO standards can be found on the following webpage:

<https://www.barnet.gov.uk/citizen-home/housing-and-community/private-housing/landlords/houses-multiple-occupation.html>

Front doors: The insertion of an additional front door tends to unbalance the appearance of the house.

As shown in Figure 13, avoid replacing the existing front door of the property with two doors adjacent to one another. If possible, additional letterboxes should be sited internally. On especially large properties or those on corner plots, it may be possible for each unit to have its own front door on different sides of the house without detracting from the appearance of the property. Each new residential unit should be self-contained, with its own lockable door.

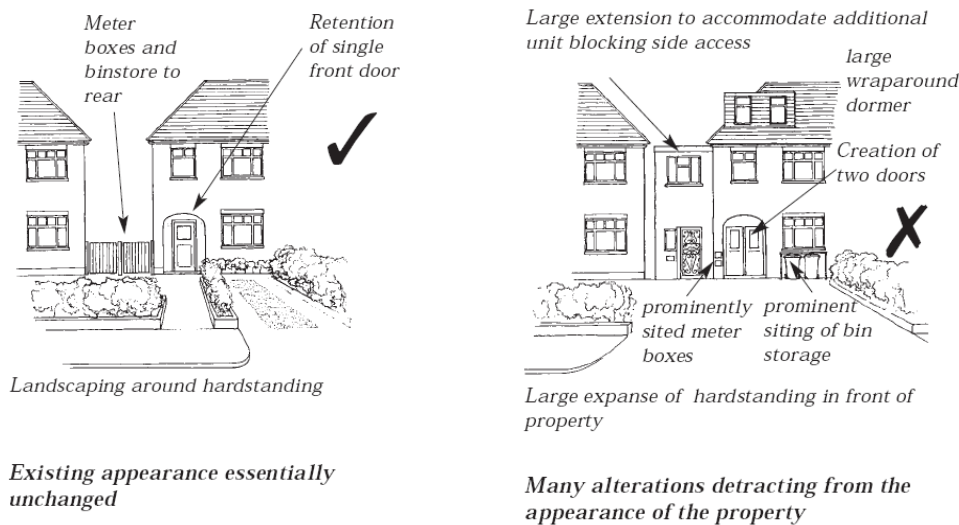

Figure 13 – Respecting Existing Appearance of Front of Properties

Extensions and roof alterations: Large extensions or alterations to the roof are unlikely to be acceptable. A rooflight may be a much less obtrusive way of making a loft space usable than a dormer window. More guidance is provided at para 14.29.

2. Internal layout

15.13 Subdivision requires careful consideration of the layout of each unit and the size and features of the rooms, so that the proximity of the new units to each other does not cause their occupants or neighbours undue disturbance.

Minimum size of unit: Appendix 2 (Table 1.3) sets down a minimum floor area of 39m² (where a studio has a shower room instead of a bathroom, the floor area may be reduced from 39m² to 37m²) for any new dwelling created through a residential conversion, including studio flats.

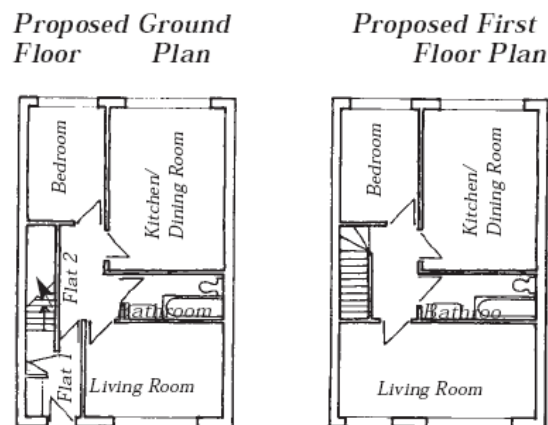

Floor layout should ensure that Living Rooms are above one another

Figure 14 – Appropriate Room Layouts for Flat Conversions

Room arrangement: As shown in Figure 14 rooms should generally lead off a hall or corridor, so that each can be accessed independently. Rooms should be located in accordance with the stacking principles highlighted in para 15.13 above in order to avoid additional noise and disturbance to neighbours.

The upper flat should be accessed from an internal set of stairs. The design of the flats must allow easy and unrestricted movement within the property, which means for example the avoidance of steep or narrow stairs and passageways, or difficult changes in level.

The design of flats in converted properties must make allowance for:

Sound-insulation: In order that the occupants of a conversion do not experience a noise nuisance, walls and floors separating dwellings should be adequately insulated so as to comply with the standards set down in the Building Regulations.

Fire regulations: Building Regulations approval is required for structural alterations and fire precautions, including the need for fire proofing of the floors and the wall between the two flats. If the conversion involves more than two storeys, then adequate provision must be made for a secondary means of escape from fire.

Plumbing and drainage: Building Regulation approval will be required for facilities such as the new bathroom.

Thermal SAP requirements: Building Regulation approval will also be required for the provision of adequate thermal insulation.

3. Access to a garden

15.14 The amenity space standards Table 1.2 in Appendix 2 should normally be applied to conversion properties. For flats, this standard is 5m² per habitable room. Refer to section 8 and the SD&C SPD for detailed standards and how they are applied.

- 15.15 Adequate access to the garden area should normally be available and maintained for the occupiers of each unit. Access to the garden for the upper flat in detached or semi-detached houses is usually best provided by means of a side access. However, in the case of a terraced house, this may necessitate an alternative means of access such as an external staircase. This will only be acceptable where the addition of such a staircase does not unduly detract from the appearance of the property and does not cause demonstrable harm to residential amenity and neighbouring resident's amenities. Any proposal for an external staircase would be considered on its own particular merits.

4. Car parking

- 15.16 Adequate provision should be made for off street car parking and it should be provided in accordance with Barnet's residential parking standards (Policy DM17).
- 15.17 Where, houses in a particular locality are characterised by planted front gardens, hardsurfacing to provide car parking is likely to be detrimental to this character and will be resisted. More information on hardstandings is set out in section 16 of this SPD.

5. Bin storage

- 15.18 As paras 11.10 and 11.11 above explain in detail, waste and recycling storage areas should normally be integrated within the building or provided on site but out of sight (and screened within an enclosure or by landscaping as shown in figure 15) avoiding landscaped garden areas in front of dwellings. Sensitive use of landscaping can soften the impact of bin storage areas when it is necessary for them to be sited to the front of a property.

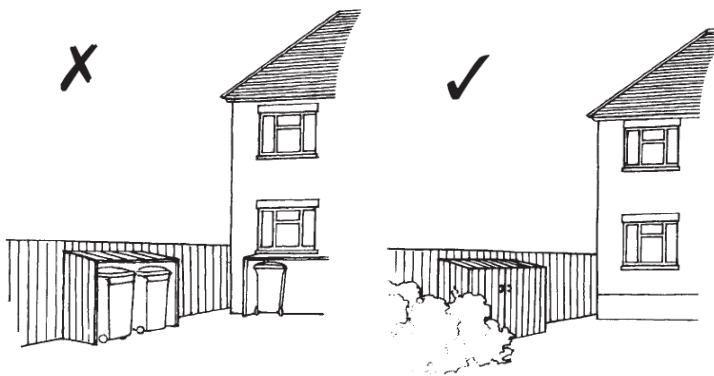

Figure 15: examples of an integration of waste and recycling storage areas

6. Gas & electricity meter boxes

- 15.19 More than one meter box on the front of a house can look unsightly. Where possible and safe, meter boxes should be located partially buried at the foot of the house wall to the front, or on the side of the property.

7. Security & crime prevention

- 15.20 For design solutions for improving security and preventing crime please refer to paras 7.7 – 7.9 in section 7 above for further information.

Principles

- conversions of houses into flats or HMOs, in roads characterised by houses will not normally be appropriate
- consideration should be given to local character and surroundings and conversions that harm this, (due to cumulative impacts of such conversions) will be refused
- the unit size should normally comply with Barnet’s space standards highlighted in Appendix 2
- usable amenity space should normally be provided for the occupiers of all units
- consideration should be given to the necessary provision and associated activities such as car and cycle parking spaces, storage, hardsurfacing and refuse store at the earliest stage of design
- where conversion take place, any impact on the amenity of future residents and neighbouring properties should be minimised.

16. Hardstandings and vehicular crossovers

“Barnet’s Characterisation Study identified the severe impact of off-street car parking and consequent loss of front gardens on the dominating street typologies”. (Barnet Core Strategy para 10.7.1)

- 16.1 This section revises and updates Barnet’s Design Guidance Note 3 on Hardstandings and Vehicular Crossovers. This section deals with the design of hardstandings for parking vehicles outside domestic properties and the provision of access to the hardstanding.
- 16.2 From 1 October 2008 permitted development rights changed for hard surfacing of front gardens. The installation or renewal of a hard surface of more than 5 square metres of domestic garden with an impervious material requires an application for full planning consent, unless provision is made to direct run-off water from the hard surface to a permeable, or porous area or surface within the curtilage of the dwelling house. The use of permeable material would be considered permitted development.
- 16.3 Front gardens contribute positively to the aesthetic charms and character of streetscapes and the setting of individual groups of properties throughout the Borough.. Increased car ownership and demand for parking spaces has put pressure on the use of off-street car parking, leading to loss of on-street parking provision as there will not be general use of the new private space (s).
- 16.4 Front gardens provide an important physical boundary between houses and the public realm. They can enhance privacy as well as filtering out noise and air pollution. Front gardens with perimeter walls, hedges or fences can offer safer spaces in which children can play as well as contribute to biodiversity.

Hardstandings

- 16.5 Gardens help to reduce the risk of flash flooding by soaking up an average of 10 litres of rainwater per minute (Royal Horticultural Society). Soft landscaping prevents water running away from gardens onto the highway. The Sustainable Design and Construction SPD (section 2.15.3) advises that new developments should normally utilise environmentally friendly methods of design and construction to help mitigate the impacts of climate change which causes increased rainfall, potential flooding and water course pollution. Permeable materials and sustainable urban drainage systems (SUDS) can be applied to hardstandings easily and relatively cheaply.
- 16.6 The following issues need to be considered when designing the layout and choosing the right materials for a hardstanding:

a. Preserving local character and retaining existing planting

- 16.7 As shown in Figure 16 the hardstanding should maintain a balance between hard and soft landscaping and should contribute positively to the streetscene.
- the area intended for the hardstanding should be the minimum space necessary to allow a vehicle to be parked
 - a hardstanding impact can be lessened by retaining mature trees and shrubs or creating areas of new planting

Figure 16 Design of Appropriate Hardstanding

Good design: Using permeable gravel for the hardstanding whilst retaining vegetation creates a colourful and pleasant street environment.

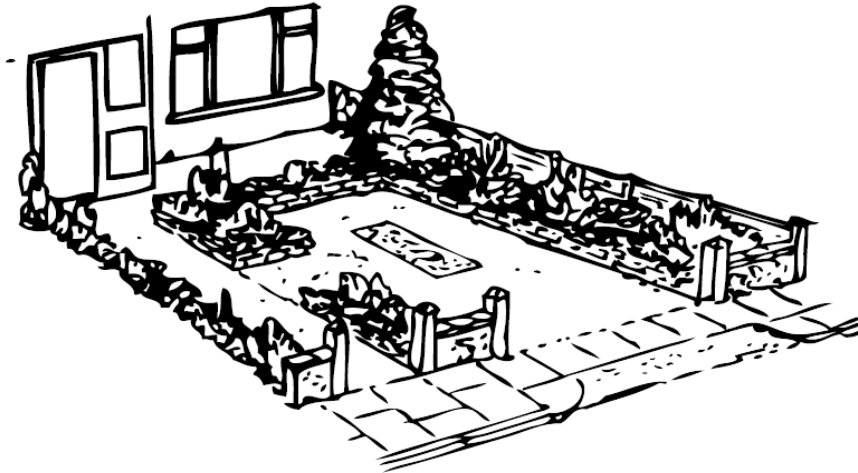

Bad design: Completely paving over your garden reduces the surface area that can absorb rain and detracts from the attractiveness of the streetscape.

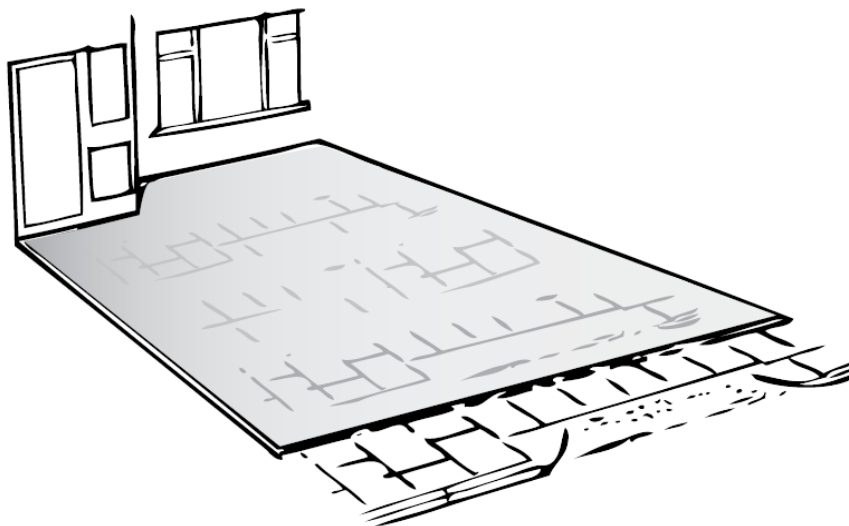

- a planted strip or hedge between the vehicular and pedestrian access or around the fringe can help to break-up the appearance of the hardstanding and may be used to help screen the vehicle
- pedestrian gates should be retained and any new or existing walls, fences or other boundary features should reflect the style, features, sympathetic materials of the existing area and may require planning permission.

b. Providing level access, ensuring safety and crime reduction

16.8 Consideration should be given to movement of people and vehicles entering and leaving the hardstanding as well as protecting the wellbeing and security of occupants and the property. The following advice should be considered:

- allow good visibility for cars leaving the hardstanding. Vegetation or other features such as gates and walls should not be over 1m high within 2m on either side of the entrance to the hardstanding

- cars should not overhang the pavement, nor block the entrance to building and a clear pathway should be provided at the entrance to a building
- landscaping, including shrubs, should not impede natural surveillance and the building front should be open to view. Shrubs that have a mature growth height of no more than 1.5m and trees that have no foliage below 2m are an ideal choice for maintaining an eye level field of vision.

Vehicular crossovers

- 16.9 For a new vehicular access, households require a crossover to be constructed (dropping the kerb) to allow vehicles to access the hardstanding across the pavement. An application for a crossover on a classified road must first be made for an approval by the council's Crossovers team in the Highways department.
- 16.10 In some circumstances constructing a hardstanding is considered to be permitted development and does not require full planning permission. Planning permission is likely to be required if the hardsurfacing also requires significant level changes. Planning permission will be required for any type of new hard standing (e.g. patios, driveways or decking) which is 5m² or larger; or repair an area of 5m² or more of existing hard standing and if the area is between the principle elevation and the highway; and any rainwater runoff would end up going down the drains.
- 16.11 The area needed to park a car should be a minimum of 2.4m in width to allow parking at right angles to the footway. It is advised to leave a clear space of approximately 500mm between any vehicle and the public highway and at least 1m between the hardstanding and the front of the property.
- 16.12 For an amendment to an existing access the area needed to park should be sufficient to ensure that the vehicle can be parked at right angles to the footway and does not overhang the public highway. It would be preferable to leave a clear space between any vehicle and the public highway, and a gap between the hardstanding and the front of the property

Principles

- **Although planning approval can be given for a hardstanding, a separate crossover application will need to be submitted to and approved by the Highway Authority for the access off the public highway. Therefore please ensure that the crossover team has approved a crossover before converting the front garden into hardstanding for car parking.**
- **hardstandings should relate to the property they form part of and minimise flooding.**
- **planning applications for hardstanding would be refused if considered to be harmful to the local character and unsafe for pedestrians crossing.**

17. Planning permission and other issues

Planning permission

- 17.1 It's always advisable to check with the council before proceeding with works or submitting an application for a Certificate of Lawful Development (see below). Householders should take into considerations the good practice and advice contained in this SPD. Consent may also be required separately under the Building Regulations.
- 17.2 Information on permitted development, types of planning permissions and the legal background to planning can be accessed free of charge at the “planning portal” website on <http://www.planningportal.gov.uk>. Formalised written pre-application advice is also available on major, complex or medium-scale development proposals, and certain planning and development briefs. The council's duty planner (check Barnet's website for their availability and timings) can advise on relevant procedures and fees. Application forms may also be downloaded from <http://www.barnet.gov.uk>.
- 17.3 When a planning application is registered, the council normally consults neighbours, erects a site notice and sometimes advertises the proposal in the local press. The planning application file held by the authority is a public document and any member of the public can view all the information placed on it.

Design process and planning submission requirements

- 17.4 The design process should be analysis-based, context-driven and creative, to produce the highest quality residential design. At the outset, the developer/designer should consider:
- the policy framework (national/London Plan/local)
 - existing area-based policies and guidance if applicable (e.g. Area Action Plans, Conservation Area Character Appraisals, Planning Briefs and relevant SPDs)
 - best practice guidance and examples (e.g. By Design, Building for Life, The Design Wayfinder)
- 17.5 Design and Access Statements provide opportunities to demonstrate that proposals are based on a thorough design process. A key part of the statement is an explanation of how local context including building styles, scale, massing, height, materials, layout, access, trees, landscape features, open spaces, landmarks, views and heritage assets have influenced the final design.
- 17.6 As part of the Design Statement for planning applications for major schemes (10 or more dwellings), the council will expect applicants to submit a response to the Building for Life questions. The council also encourages applicants to respond to these criteria on smaller applications.
- 17.7 Further information on the requirements for Design and Access Statements is contained in Appendix 3. Additionally, CABI guidance can be downloaded from the CABI website: <http://www.cabi.org.uk/publications/design-and-access-statements>. Barnet's Design and Access Statement Guidance Note to assist those making planning

applications can be downloaded from <http://www.barnet.gov.uk/design-access-guidance-oct07.pdf>

- 17.8 It is recommended that applicants contact the council at an early stage to discuss submission requirements and initiate the design process. A pre-application meeting is advisable on larger sites. A current list of fees for pre-application advice is available on the Barnet's website (www.barnet.gov.uk/) or the Duty Planning Officer on 0208 359 3000.

Other issues to consider

Conservation areas

- 17.9 A Conservation Area is an area identified and designated by the local authority as being of special architectural or historic interest or particularly high environmental quality. Within conservation areas different 'permitted development' rules apply, and because of their particular character, the council will require a higher standard of design and materials than elsewhere.
- 17.10 When assessing proposals in these areas, the council will have special regard to the desirability of preserving or enhancing their character or appearance. Conversions in such areas therefore should be of a standard and type of design compatible with the character of the particular area. Some conservation areas are subject to what is known as 'Article 4 Directions'. These directions require that planning permission is obtained for development that would otherwise constitute 'permitted development'. Further information and advice including Conservation Area Appraisals, where appropriate, are available from the Planning Service.
- 17.11 For residents of the *Hampstead Garden Suburb* any external change to a property, including restoration of original work is likely to require the formal consent of the Hampstead Garden Suburb Trust as well as planning permission. The council and the Trust have produced a design guidance leaflet for the Suburb which is available on Barnet council's website.
- 17.12 Within The Bishop's Avenue, proposals for new development will be expected to: take the form of detached houses within substantial plots and be of a scale and design compatible with the established character of The Bishop's Avenue; utilise existing access points, avoiding the formation of additional or widened vehicle access points; retain existing plot widths, avoiding sub-division of existing sites; retain existing landscaping, established trees and shrubs; avoid the use of high security walls, gates and fencing; preserve a significant degree of separation between buildings; and take into account the council's character appraisal statement on The Bishop's Avenue. Flatted development on sites occupied by single family homes will be strongly resisted.

Listed and Locally Listed Buildings

- 17.13 In Barnet there are over 2,200 Listed Buildings and 1,600 buildings of local importance. The council's Conservation team can provide guidance on properties that are included in the National Statutory List, the Local List or the Buildings at Risk Register.
- 17.14 Internal and external alterations or extensions (including any demolition) which affects the character of a Listed Building will require Listed Building Consent, in addition to any planning permission which may be necessary. The fact that a proposed extension may

itself be ‘permitted development’ does not negate the need to obtain Listed Building Consent. Proposals for the conversion of a listed building are likely to be considered appropriate only if the internal layout and external appearance of the building lends itself to this use. Failure to obtain Listed Building Consent is a criminal offence punishable by a fine or even imprisonment.

17.15 With regard to Locally Listed Buildings the council will apply a presumption in favour of retention.

Green Belt, Metropolitan Open Land and Flood Defence Consents

17.16 Barnet contains extensive areas of high quality Green Belt comprising of predominantly open land but also covering existing settlements such as Totteridge, Mill Hill and Monken Hadley.

17.17 The fundamental aim of Green Belt policy is to prevent urban sprawl by keeping land permanently open and preserving the special character of existing townscapes. The council has consistently protected the Green Belt and adjoining land by resisting inappropriate development including poorly designed and large extensions to dwellings, in accordance with the national policies.

17.18 Metropolitan Open Land (MOL) is a designation which covers areas of major open spaces in Barnet and it is appropriate to apply the principles of development management in the Green Belt to MOL as well.

17.19 Before proceeding with any development work, it is advisable to check if the property is located in or adjacent to the Green Belt or MOL by looking at the borough’s Local Plan. In these circumstances it is particularly important to ensure that any proposals for altering your property are well designed and do not detract from the visual amenity of the surrounding area. Details on the extent of extensions in the Green Belt are highlighted in section 14.51.

17.20 In addition to planning permission (or permitted development), under the terms of the Water Resources Act 1991, and the Thames Region Land Drainage Byelaws 1981, prior written consent is required from the Environment Agency for any proposed works or structures, in, under, over or within eight metres of the top of the bank of any watercourse designated by the Environment Agency as a ‘main river’. A main river does not necessarily relate to the size of the watercourse, and can include smaller streams and culverted channels. The location of main rivers in Barnet can be found on the ‘What’s in your backyard?’ section of the Environment Agency website: <http://www.environment-agency.gov.uk/homeandleisure/37793.aspx>.

17.21 It is recommended that developers/applicants seek the advice of the Environment Agency prior to submitting for planning permission or permitted development, as their consent may not be granted for the intended works.

Considering existing trees

17.22 There is a wealth of evidence on the benefits of accessible woodland and high canopy cover, including improving: physical and mental health; air quality; water quality; reducing run-off; shading and cooling through evapotranspiration; as well as the more obvious benefit of improving biodiversity. Guidance on the retention and planting of

trees in new development can be found in the report *Residential Development and Trees* published by the Woodland Trust.

- 17.23 Trees and grass verges are an important feature of many streets and can provide an important habitat for birds. Try not to disturb the ground near a tree or large shrub. If intending to undertake excavation or building works, always contact the council's Tree and Landscaping section (within the Planning Department) to see if your proposal affects any tree (or its roots) and if any trees are protected by a Tree Preservation Order or by virtue of being locally listed within a conservation area. During building operations the council will expect that adequate precautions are taken to ensure that existing trees and their root systems and other landscape features are protected. Consent will probably be required for any work affecting trees, including the cutting of roots.

Avoiding disputes with neighbours

- 17.24 The concerns of neighbours and adjoining occupiers are important factors in decision making. The council recommends early discussions about the design of development in particular how it will look and how it will impact on your neighbour's daylight/sunlight, outlook and gardens.
- 17.25 If you intend to carry out work to an existing wall or structure which is shared with another property, build a free-standing wall or a wall up to or astride the boundary with a neighbouring property, or excavate near a neighbouring building, neighbours should be notified under the provisions of the Party Wall Act 1996. It should be noted that issues that relate to boundary disputes and land ownership are not planning matters.
- 17.26 It is also important to consider how any building works might affect your neighbours. Some inconvenience may be inevitable, however keeping noise and disturbance to a minimum having regard to matters such as working hours and construction related parking will greatly assist relations. For more information please look at our "Site Construction guidance for Householders and Developers" on the council's website www.barnet.gov.uk.

Certificate of lawful development

- 17.27 If you are in any doubt as to whether planning permission is required, you can apply to the council for a certificate of lawful development. The certificate confirms whether or not planning permission would be required for the proposal. The appropriate forms and an explanatory leaflet are available from the council and should be submitted with the appropriate fee.

Making a decision

- 17.28 When the council comes to making a decision on a case there are two different ways this can happen. Most planning applications are approved or refused by officers acting on authority delegated to them by the council. Where this is the case the council will try to make a decision within an 8 week period starting from the date the application is validated. However, where several objections are received, approval is not given without full consideration by the relevant Planning Committee of councillors.

- 17.29 If an application is refused then the applicant will have a right of appeal against the decision to the Planning Inspector. An appeal against any planning conditions imposed can also be made. The Planning Inspectorate details and guidance in relation to lodging an appeal are normally enclosed with the decision notice.

Enforcement

- 17.30 If works subject to planning control are carried out without the written consent of the council, the council has the power to ensure that the breach of planning legislation is remedied. Failure to obtain planning permission or to reflect the planning permission (i.e. that it accurately represents what is shown on the approved planning drawings) can lead to enforcement action. Enforcement action may compel a building to be returned to its original form or rebuilding in accordance with the planning permission.
- 17.31 In addition to any planning requirements, if a hardstanding is used for parking vehicles without there being a properly constructed crossover, under Section 184 of the Highways Act (1980) the local highways authority can require a crossover to be constructed and recover any costs from the property occupier.
- 17.32 In the case of a listed building, any person who carried out or caused the works to be carried without or not in accordance with listed building consent is liable to prosecution in addition to enforcement proceedings.

PART 4

Appendices

Appendix 1: Building for Life¹²

BfL12 comprises of 12 questions, with four further questions under each main heading that reflect BfL12's vision of what new housing developments should be: attractive, functional and sustainable places. Further details are available at:

http://www.hbf.co.uk/fileadmin/documents/briefings/BfL_A4_booklet_singlepages_.pdf

Integrating into the neighbourhood

1. Connections

Does the scheme integrate into its surroundings by reinforcing existing connections and creating new ones; whilst also respecting existing buildings and land uses along the boundaries of the development site?

1a Where should vehicles come in and out of the development?

1b Should there be pedestrian and cycle only routes into and through the development? If so where should they go?

1c Where should new streets be placed and could they be used to cross the development site and help create linkages across the scheme and into the existing neighbourhood?

1d How should the new development relate to existing development? What should happen at the edges of the development site?

2. Facilities and services

Does the development provide (or is it close to) community facilities, such as shops, schools, workplaces, parks, play areas, pubs or cafes?

2a Are there enough facilities and services in the local area to support the development? If not, what is needed?

Where new facilities are proposed:

2b Are these facilities what the area needs?

2c Are these new facilities located in the right place? If not, where should they go?

3. Public transport

Does the scheme have good access to public transport to help reduce car dependency?

3a What can the development do to encourage more people (both existing and new residents) to use public transport more often?

3b Where should new public transport stops be located?

4. Meeting local housing requirements

Does the development have a mix of housing types and tenures that suit local requirements?

4a What types of homes, tenure and price range are needed in the area (for example, starter homes, family homes or homes for those downsizing)?

4b Is there a need for different types of home ownership (such as part buy and part rent) or rented properties to help people on lower incomes?

Creating a place

5. Character

Does the scheme create a place with a locally inspired or otherwise distinctive character?

5a How can the development be designed to have a local or distinctive identity?

5b Are there any distinctive characteristics within the area, such as building shapes, styles, colours and materials or the character of streets and spaces that the development should draw inspiration from?

6. Working with the site and its context

Does the scheme take advantage of existing topography, landscape features (including water courses), wildlife habitats, existing buildings, site orientation and microclimates?

6a Are there any views into or from the site that need to be carefully considered?

6b Are there any existing trees, hedgerows or other features, such as streams that need to be carefully designed into the development?

6c Should the development keep any existing building(s) on the site? If so, how could they be used?

7. Creating well defined streets and spaces

Are buildings designed and positioned with landscaping to define and enhance streets and spaces and are buildings designed to turn street corners well?

7a Good streets and spaces are created by enclosing them with buildings and a strong landscaping scheme. Are buildings used to create enclosed streets and spaces?

7b Good buildings 'turn' corners. Do buildings turn corners well?

7c Do all fronts of buildings, including front doors face the street?

8. Easy to find your way around

Is the scheme designed to make it easy to find your way around?

8a Will the development be easy to find your way around? If not, what could be done to make it easier to find your way around?

Street and home

9. Streets for all

Are streets designed in a way that encourage low vehicle speeds and allow them to function as social spaces?

9a Are streets pedestrian friendly and are they designed to encourage cars to drive slower and more carefully?

9b Are streets designed in a way that they can be used as social spaces, such as places for children to play safely?

10. Car parking

Is resident and visitor parking sufficient and well integrated so that it does not dominate the street?

10a Is there enough parking for residents and visitors?

10b Is parking positioned close to people's homes?

10c Are any parking courtyards small in size (generally no more than five properties should use a parking courtyard) and are they well overlooked by neighbouring properties?

10d Are garages well positioned so that they do not dominate the street scene?

11. Public and private spaces

Will public and private spaces be clearly defined and designed to be attractive, well managed and safe?

11a What types of open space should be provided within this development?

11b Is there a need for play facilities for children and teenagers? If so, is this the right place or should the developer contribute towards an existing facility in the area that could be made better?

12. External storage and amenity space

Is there adequate external storage space for bins and recycling, as well as vehicles and cycles?

12a Is there enough storage space for bins and recycling, as well as vehicles?

BfL 12 is also designed to help local planning authorities assess the quality of proposed and completed developments. Schemes that are considered to have achieved 12 'greens', will be eligible for 'Building for Life Diamond' status, as exemplars giving developers and local authorities the opportunity to acknowledge and promote good design. Diamond status will be available prior to build completion, offering developers the opportunity to market their developments using Building for Life.

Appendix 2: Tables

Table 1.1: London Plan Sustainable Residential Quality Density Matrix			
Setting	Public Transport Accessibility Level (PTAL)		
	0 to 1	2 to 3	4 to 6
Suburban¹	150-200 hr/ha	150-250 hr/ha	200-350 hr/ha
3.8-4.6 hr/unit	35-55 u/ha	35-65 u/ha	45-90 u/ha
3.1-3.7 hr/unit	40-65 u/ha	40-80 u/ha	55-115 u/ha
2.7-3.0 hr/unit	50-75 u/ha	50-95 u/ha	70-130 u/ha
Urban²	150-250 hr/ha	200-450 hr/ha	200-700 hr/ha
3.8-4.6 hr/unit	35-65 u/ha	45-120 u/ha	45-185 u/ha
3.1-3.7 hr/unit	40-80 u/ha	55-145 u/ha	55-225 u/ha
2.7-3.0 hr/unit	50-95 u/ha	70-170 u/ha	70-260 u/ha
Central³	150-300 hr/ha	300-650 hr/ha	650-1100 hr/ha
3.8-4.6 hr/unit	35-80 u/ha	65-170 u/ha	140-290 u/ha
3.1-3.7 hr/unit	40-100 u/ha	80-210 u/ha	175-355 u/ha
2.7-3.0 hr/unit	50-110 u/ha	100-240 u/ha	215-405 u/ha
Setting is defined as: ¹ Suburban – areas with predominantly lower density development such as detached and semi-detached houses, predominantly residential, small building footprints and typically buildings of two to three storeys. ² Urban – areas with predominantly dense development such as terraced houses, mansion blocks, a mix of different uses, medium building footprints and typically buildings of two to four storeys, located within 800 metres walking distance of a District centre or along main arterial routes. ³ Central – areas with very dense development, a mix of different uses, large building footprints and typically buildings of four to six storeys, located within 800 metres walking distance of an International, Metropolitan or Major town centre			
Source: London Plan 2016.			

Table 1.2: Outdoor Amenity Space Requirements for Barnet	
Outdoor Amenity Space Requirements for Barnet	Development Scale
For Flats: • 5 m ² of space per habitable room.	Minor, Major and Large scale
For Houses: • 40 m ² of space for up to four habitable rooms • 55 m ² of space for up to five habitable rooms • 70 m ² of space for up to six habitable rooms • 85 m ² of space for up to seven or more habitable rooms	Minor, Major and Large scale
Development will not be permitted if it compromises the minimum outdoor amenity space standards.	Householder
In calculating outdoor amenity space the following will not be counted: shared surfaces, driveways, vehicle parking areas or hard standings, cycle storage areas ('dirty' storage) footpaths, servicing areas and refuse storage areas. In addition outdoor amenity space which does not have a reasonable level of privacy will not be considered to be usable.	
Source: Sustainable Design and Construction SPD 2012, Table 2.3 and section 2.3.2	

Table 3.3 of the London Plan and National Space Standards

Bedrooms	Bedspaces	Minimum gia (sqm)			Built-in storage (sqm)
		1 storey dwellings	2 storey dwellings	3 storey dwellings	
1b	1p	39 (37)*			1.0
	2p	50	58		1.5
2b	3p	61	70		2.0
	4p	70	79		
3b	4p	74	84	90	2.5
	5p	86	93	99	
	6p	95	102	108	
4b	5p	90	97	103	3.0
	6p	99	106	112	
	7p	108	115	121	
	8p	117	124	130	
5b	6p	103	110	116	3.5
	7p	112	119	125	
	8p	121	128	134	
6b	7p	116	123	129	4.0
	8p	125	132	138	

Notes to Table 3.3

- *Where a one person dwelling has a shower room instead of a bathroom, the floor area may be reduced from 39m² to 37m², as shown bracketed.
- The Gross Internal Area of a dwelling is defined as the total floor space measured between the internal faces of perimeter walls that enclose a dwelling. This includes partitions, structural elements, cupboards, ducts, flights of stairs and voids above stairs. GIA should be measured and denoted in square metres (m²)
- The nationally described space standard sets a minimum ceiling height of 2.3 meters for at least 75% of the gross internal area of the dwelling. To address the unique heat island effect of London and the distinct density and flatted nature of most of its residential development, a minimum ceiling height of 2.5m for at least 75% of the gross internal area is strongly encouraged so that new housing is of adequate quality, especially in terms of light, ventilation and sense of space.

Barnet Council's adopted HMO standards can be found on the following webpage:

<https://www.barnet.gov.uk/citizen-home/housing-and-community/private-housing/landlords/houses-multiple-occupation.html>

Glossary

Active Frontage A frontage which adds interest, life and vitality to the public realm. It has frequent doors and windows with few blank walls.

Amenity Element of a location or neighbourhood that helps to make it attractive or enjoyable to residents and visitors

Biodiversity The variety of plants and animals and other living things in a particular area or region. It encompasses habitat diversity and genetic diversity.

Building line The line formed by the frontages of buildings along a street. The building line can be shown on a plan or section.

Context (or site and area) appraisal A detailed analysis of the features of a site or area (including land uses, built and natural environment, and social and physical characteristics) which serves as the basis for an urban design framework, development brief, design guide or other policy or guidance.

Context The setting of a site or area, including factors such as traffic, activities and land uses as well as landscape and built form.

Curtilages The land immediately surrounding a building and directly related to it.

Design principle An expression of one of the basic design ideas at the heart of an urban design framework, design guide, development brief or a development.

Desire line An imaginary line linking facilities or places which people would find it convenient to travel between easily.

Door Canopies A roof over the front door, possibly supported by posts.

Eaves Where the roof overhangs the house wall.

Elevation The facade of a building, or the drawing of a facade.

Enclosure The use of buildings to create a sense of defined space.

Form The layout (structure and urban grain), density, scale (height and massing), appearance (materials and details) and landscape of development.

Green Belt A national policy designation that helps to contain development, protect the countryside and promote brownfield development. Development is strictly controlled in the Green Belt.

Habitable room A room within a dwelling, the primary purpose of which is for living, sleeping or dining, including kitchens where the total area is more than 13m² (including fittings), or the dining space if it is divided from the working area by a moveable partition. Rooms exceeding 20m² will be counted as two.

Height The height of a building can be expressed in terms of a maximum number of floors; a maximum height of parapet or ridge; a maximum overall height; any of these maximum heights in combination with a maximum number of floors; a ratio of building height to street or space width; height relative to particular landmarks or background buildings; or strategic views.

Hipped roof A roof formed by several adjacent inclining planes, each rising from a different wall of building, and forming hips at their adjacent sloping sides.

Human scale The use within development of elements which relate well in size to an individual human being and their assembly in a way which makes people feel comfortable rather than overwhelmed.

In-curtilage parking Parking within a building's site boundary, rather than on a public street or space.

Landmark A building or structure that stands out from its background by virtue of height, size or some other aspect of design.

Landscape The character and appearance of land, including its shape, form, ecology, natural features, colours and elements and the way these components combine. Landscape character can be expressed through landscape appraisal, and maps or plans. In towns 'townscape' describes the same concept.

Layout structure The framework or hierarchy of routes that connect in the local area and at wider scales.

Layout The way buildings, routes and open spaces are placed in relation to each other.

Legibility The degree to which a place can be easily understood and traversed (to travel or pass across)

Liveability Refers to the environmental and social quality of an area as perceived by residents, employees and visitors.

Local distinctiveness The positive features of a place and its communities which contribute to its special character and sense of place.

Massing The combined effect of the height, bulk and silhouette of a building or group of buildings.

Means of enclosures Is the separation and appropriation of land by means of a fence or a wall.

Metropolitan Open Land (MOL) MOL covers areas of major open spaces within urban area that have more than borough-wide significance for their contribution to recreation, leisure and visual amenity and which receive same presumption against development as Green belt.

Movement People and vehicles going to and passing through buildings, places and spaces. The movement network can be shown on plans, by space syntax analysis, by highway designations, by figure and ground diagrams, through data on origins and destinations or pedestrian flows, by desire lines, by details of public transport services, by walk bands or by details of cycle routes.

Natural surveillance (or supervision) The discouragement to wrong-doing by the presence of passers-by or the ability of people to be seen out of surrounding windows. Also known as passive surveillance (or supervision).

Node A place where activity and routes are concentrated often used as a synonym for junction.

Permeability The degree to which an area has a variety of pleasant, convenient and safe routes through it.

Pitched Roof A roof in the shape of an upside down 'V'.

Public Transport Accessibility Level (PTAL) A detailed and accurate measure of the accessibility of a point to the public transport network, taking into account walk access time and service availability. PTALs reflect :

- walking time from the point of interest to the public transport access points;
- the reliability of the service modes available;
- the number of services available within the catchment; and
- the level of service at the public transport access points – ie average waiting time.

Recessed Doorways Where the front door sits further back than the rest of the house's front wall, normally with a roof or a protruding first floor room above.

Scale The impression of a building when seen in relation to its surroundings, or the size of parts of a building or its details, particularly as experienced in relation to the size of a person. Sometimes it is the total dimensions of a building which give it its sense of scale: at other times it is the size of the elements and the way they are combined. The concept is a difficult and ambiguous one: often the word is used simply as a synonym for 'size'. See 'Human scale'.

Street furniture Structures in and adjacent to the highway which contribute to the street scene, such as bus shelters, litter bins, seating, lighting, railings and signs.

Topography A description or representation of artificial or natural features on or of the ground.

Urban design The art of making places. Urban design involves the design of buildings, groups of buildings, spaces and landscapes, in villages, towns and cities, and the establishment of frameworks and processes which facilitate successful development.

Urban grain The pattern of the arrangement and size of buildings and their plots in a settlement; and the degree to which an area's pattern of street-blocks and street junctions is respectively small and frequent, or large and infrequent.

Further guidance

Building for Life12, Sept 2012

http://www.hbf.co.uk/fileadmin/documents/briefings/BfL_A4_booklet_singlepages_.pdf

CABE: By Design: Urban Design in the Planning system towards better Practice, 2000

<http://www.cabe.org.uk/publications/by-design>

CLG: National Planning Policy Framework, Mar 2012

<http://www.communities.gov.uk/documents/planningandbuilding/pdf/2116950.pdf>

CLG: Supplementary Report Basement Extension – Householder Development Consents Review – Implementation of Recommendations, Nov 2008

<http://www.communities.gov.uk/publications/planningandbuilding/basementextensions>

Department for Transport: Local Transport Note 1/12 - Shared Use Routes for Pedestrians and Cyclists, Sept 2012

https://www.gov.uk/government/uploads/system/uploads/attachment_data/file/9179/shared-use-routes-for-pedestrians-and-cyclists.pdf

Design Council CABE: The Design Wayfinder, Jun 2012

<http://www.designcouncil.org.uk/our-work/cabe/localism-and-planning/design-wayfinder/>

GLA: All London Green Grid Supplementary Planning Guidance, Mar 2012

http://www.london.gov.uk/sites/default/files/ALGG_SPG_Mar2012.rtf

Environment Agency: Flood Risk Standing Advice 2012

<http://www.environment-agency.gov.uk/research/planning/82584.aspx>

Environment Agency: Planning Advice Section Dec 2012

<http://www.environment-agency.gov.uk/research/planning/default.aspx>

GLA: Connecting with Nature - the London Biodiversity Strategy, 2005

http://legacy.london.gov.uk/mayor/strategies/biodiversity/biodiversity_strategy.jsp

GLA: SPG on Housing March 2016 <https://www.london.gov.uk/what-we-do/planning/implementing-london-plan/supplementary-planning-guidance/housing>

GLA: Guidance for Residential Travel Planning in London, May 2008

<http://theihe.org/knowledge-network/uploads/Guidance-residential-travel-planning-2008.pdf>

GLA: SPG on Shaping Neighbourhoods: Play and Informal Recreation SPG, Sept 2012

<http://www.london.gov.uk/publication/shaping-neighbourhoods-play-and-informal-recreation-spg>

GLA: The London Plan, March 2016

<https://www.london.gov.uk/what-we-do/planning/london-plan/current-london-plan>

LBB: Barnet's Characterisation Study, May 2010

http://www.barnet.gov.uk/downloads/download/350/characterisation_study

LBB: Barnet's Conservation Areas webpage

<http://www.barnet.gov.uk/info/200023/conservation/975/conservation>

LBB: Barnet's Local Plan Core Strategy, Sept 2012

http://www.barnet.gov.uk/info/940354/adopted_local_plan-core_strategy_dpd/1004/adopted_local_plan-core_strategy_dpd

LBB: Barnet's Local Plan Development Management Policies, Sept 2012

http://www.barnet.gov.uk/info/940355/adopted_local_plan-development_management_policies_dpd

LBB: Barnet's Priority Estates and Regeneration Projects webpage

http://www.barnet.gov.uk/info/823/regeneration_projects/840/regeneration_projects

LBB: Brent Cross Cricklewood Regeneration Framework webpage

http://www.barnet.gov.uk/info/940028/cricklewood_brent_cross/530/cricklewood_brent_cross

LBB: Building Control webpage

http://www.barnet.gov.uk/info/200011/building_control/974/building_control

LBB: Colindale Area Action Plan, Mar 2010

http://www.barnet.gov.uk/info/940272/colindale_aap/744/colindale_aap

LBB: Mill Hill East Area Action Plan, Jan 2009

http://www.barnet.gov.uk/info/940168/mill_hill_east_aap/586/mill_hill_east_aap

LBB: Open Space, Sport and Recreational Facilities, Dec 2009

http://www.barnet.gov.uk/downloads/download/348/open_space_assessment

LBB: Sustainable Design and Construction SPD, 2012

http://www.barnet.gov.uk/downloads/download/518/sustainable_design_and_construction_spd_documents

ODPM: Safer Places: The Planning System and Crime Prevention, 2004

http://www.securedbydesign.com/pdfs/safer_places.pdf

Police initiative: Secured by Design, Website Model

<http://www.securedbydesign.com/>

TfL: Advice note: Travel Planning for Residential Developments - New Way to Plan, 2011

<http://www.lscop.org.uk/newwaytoplan/travelplan.html>

Other useful publications and websites

List of Design Guidance Notes

- DGN 1: Advertising and Signs (1993)
- DGN 2: The Selection and Siting of Satellite Antenna (1993)

- ~~DGN 3: The Construction of Hard-standings (driveways) and Vehicle Crossovers (dropped kerbs) (2011)~~ **replaced by a section 15 of this SPD.**
- DGN 4: The Removal or Alteration of Chimney Stacks (1993)
- ~~DGN 5: Extensions to Houses (2010)~~ **replaced by section 13 of this SPD.**
- DGN 6: The Replacement of Windows and Doors (1993)
- ~~DGN 7: Residential Conversions (1994)~~ **replaced by a section 14 of this SPD.**
- DGN 8: Materials and Colour (1995)
- DGN 9: Walls, Fences and Gates (1994)
- DGN 10: Shopfronts (2011)
- ~~DGN 11: Porches (1995)~~ **replaced by section 13.61- 65 of this SPD.**
- DGN 12: Designing to Reduce Crime (2000)

All DGN notes are available to download from the council's website:
http://www.barnet.gov.uk/downloads/download/721/design_guidance

List of Conservation Area Character Appraisal Statements

1. College Farm (Map - Jan1989)
2. Cricklewood, Railway Terraces (March1998)
3. Finchley Church End (August 2011)
4. Finchley Garden Village (appraisal underway)
5. Glenhill Close (Sept 2002)
6. Golders Green Town Centre (July 2011)
7. Hampstead Garden Suburb (Oct 2010)
8. Hampstead Garden Suburb, Bishop's Avenue (Feb 1999)
9. Heath Passage (Map - Dec 2009)
10. Hendon Church End (2012)
11. Hendon The Borroughs (2012)
12. Mill Hill (April 2008)
13. Monken Hadley (Jan 2007)
14. Moss Hall Crescent (Map - Feb 2003)
15. Totteridge (May 2008)
16. Watling Estate (July 2007)
17. Wood Street (July 2007)

All Conservation Area Character Appraisal Statements are available to download from the council's website:
http://www.barnet.gov.uk/downloads/511/conservation_areas

Useful contacts

For further information and any specific queries, please contact:

The Planning Service duty planner at:

Planning Reception
Barnet House, 2nd Floor
1255 High Road, Whetstone N20 0EJ

Tel: 020 8359 4561
Fax: 0870 889 6818
Email: planning.enquiry@barnet.gov.uk

The Planning Duty Officer is available on Monday, Wednesday & Friday mornings from 9am to 1pm

Listed Building and Conservation Area enquiries:

Conservation and Heritage Team
Tel: 020 8359 3000
Fax: 0870 889 6818
Email: planning.enquiry@barnet.gov.uk

Building Regulation enquiries:

Building Regulation Service
Tel: 020 8359 4500
Fax: 0870 889 7462
Email: building.control@barnet.gov.uk

For a comprehensive source of information concerning planning and building control matters please visit the council's planning pages online www.barnet.gov.uk or Government's planning portal website at www.planningportal.gov.uk

Copies of this document can be viewed at any Barnet library and at the planning reception which is located at

Barnet House 2nd floor
1255 High Road, Whetstone
London N20 0EJ

The reception is open Monday to Friday:
9.00am to 5.00pm

Contact details

Strategic Planning (Planning and Housing), 1255 High Road, Whetstone, London N20 0EJ

Or email: forward.planning@barnet.gov.uk

Or contact us on: 0208-359-4990